



INSTRUMENT PROFICIENCY CHECK

Study Guide

J D Price, CFII, MEI, ATP

This publication is for informational purposes only, and is not intended to substitute for any approved aircraft flight manual, Flight Service briefing, competent flight instruction, or regulations published by the Federal Aviation Administration. The navigational charts used herein are not current and should not be used for navigation.

Limitation of Liability

The author, J D Price, assumes no responsibility for errors or omissions. In addition, liability is not assumed for damages resulting from the use of the information herein.

TABLE OF CONTENTS

The Instrument Proficiency Check

What you can expect

Instrument Rules & Regulations

Charts and the ATC System

NOTAMs and Before Takeoff Planning

Takeoff & Departure

Holding

STARs

Instrument Approaches

GPS World

The Instrument Proficiency Check

What you can expect

14CFR part 61.57(d)

The instrument proficiency check must be:

- In an aircraft that is appropriate to the aircraft category – or
- In a flight simulator or flight training device that is representative of the aircraft category

The instrument proficiency check must be given by either:

- An examiner
- A person authorized by the U.S. Armed Forces to conduct instrument flight tests, provided the person being tested is a member of the U.S. Armed Forces
- A company check pilot who is authorized to conduct instrument flight tests under part 121, 125, or 135 of this chapter or subpart K of part 91 of this chapter, and provided that both the check pilot and the pilot being tested are employees of that operator or fractional ownership program manager, as applicable
- An authorized instructor, or
- A person approved by the Administrator to conduct instrument practical tests.

A proficient instrument pilot must possess knowledge and skill in three distinct, but interrelated, areas:

- **Aircraft control skills** (i.e., basic attitude instrument flying (BAI) – crosscheck (including effective scan), interpret, and control. If the pilot flies in “glass cockpit” aircraft, the discussion should include appropriate and effective scanning techniques for these aircraft.
- **Aircraft systems knowledge** (i.e., knowledge and proficiency in instrument procedures and aircraft systems, including GPS/FMS, autopilot, Datalink)
- **Aeronautical decision-making (ADM) skills** (i.e., higher order thinking skills, flight planning & flight management, cockpit organization, weather analysis/anticipation).



The instructor shall use the standards in the [Instrument Rating Practical Test Standards \(PTS\)](#).

The PTS task chart requires

- One precision approach
- One non-precision approach,
- Loss of primary flight instruments.
 - If a multi-engine aircraft is used for the IPC, a single-engine approach is essential.

Got GPS?

In a technically advanced aircraft, the pilot should be able to understand the significance of “ENR,” “TERM,” and “APR.”

He or she should correctly manage the sequence for selecting navigation source and arming the approach mode of the autopilot.

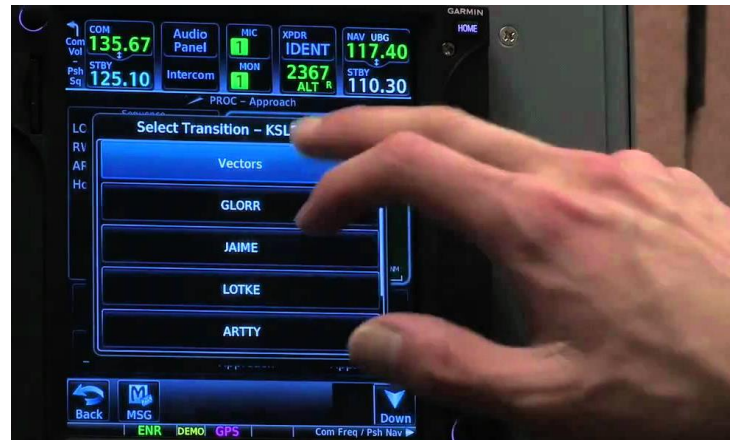

You can learn more by reading the FAA's “Instrument Proficiency Check (IPC) Guidance” [Download it HERE](#)

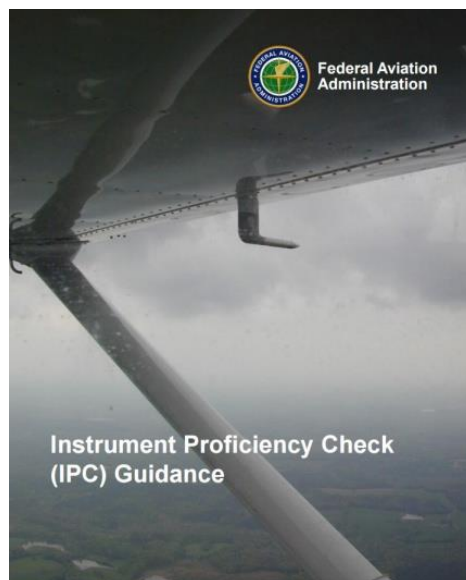



The CFI-I

He or she should develop a scenario that incorporates as many required TASKS as practical to access the pilot's Aeronautical Decision-Making (ADM) and Risk Management skills during the IPC. The client should demonstrate proficiency in the use of the autopilot, coupled approaches and Cockpit Resource Management (CRM).

How Often Should You have an IPC?

Doug Stewart is the “**National Certificated Flight Instructor of the Year for 2004**”. An eight-time Master Certified Flight Instructor, Gold Seal Instructor, and Designated Pilot Examiner, he is based at the Columbia County Airport (1B1) in Hudson, NY. He said this about maintaining instrument proficiency:

*“I certainly highly recommend getting an IPC once **every six months**, even if you fly IFR once a week. It doesn't hurt to get another opinion; to get someone else to evaluate your IFR flying and your IFR skills. Obviously, if you aren't flying frequently, it behooves you all the more to do it.”*



Instrument Regulations

Staying IFR Current

Within the previous six calendar months, (the beginning of this six-month window starts on the 1st), you must have:

- Completed an IPC, or
- Maintained IFR currency by logging:
 - Six Instrument Approaches,
 - Holding procedures, and
 - Course interceptions & tracking



Maintaining IFR currency can be accomplished:

- In actual instrument conditions,
- In simulated Instrument conditions (using a hood or *Foggles*), as long as you have a qualified safety pilot, or
- In an Aviation Training Device (ATD), Flight Training Device (FTD), or Full Flight Simulator (FFS) * if—within six calendar months you perform the same tasks that are currently required for a plane. The three extra hours of instrument time and the unusual attitude tasks are no longer required. The requirement to have a CFII present also has been removed.
 - To stay current using an ATD, you simply need to perform the following tasks within six calendar months:
 - six instrument approaches
 - holding procedures and tasks
 - intercepting and tracking courses through the use of navigational electronic systems





* The simulator must be at least a desktop simulator. The Redbird TD Flight Simulator is a good option.

The aircraft or simulator used for the IPC, or for maintaining IFR currency, is **category specific**. That is, you cannot become or remain IFR current in a helicopter or helicopter simulator and expect that currency to be valid in an airplane.



Safety Pilots do not require an instrument rating, but must have:

- A private pilot certificate with **category** and **class** ratings appropriate to the aircraft being flown, and
- A current medical or, as of 22 Dec 2022, BasicMed.

After the flight with a safety pilot, log the:

- Amount of simulated instrument time,
- Airport(s) where you flew the approaches,
- Types of instrument approaches, and
- The safety pilot's name.

Lost Currency & Grace



If you failed to fly six instrument approaches in the last six-month window, you still have another six months – **a grace period** – to meet IFR currency requirements.

During the grace period, you can only dream of filing an IFR flight plan until, in **simulated** instrument conditions, you log enough approaches to bring the six-month window total to six, plus holding, course interceptions and tracking.

If you fail to become current in the grace period, you must take an IPC before you file your next IFR flight plan.

Air Worthiness – PIC Responsibilities (FAR 91.413)

The PIC must make sure that his/her aircraft is airworthy. This includes ensuring that:

- The aircraft has received an Annual Inspection within the past 12 months. (The annual expires the last day of the 12th month). (FAR 91.409)
- VFR or IFR – the transponder has been tested and inspected within the past 24 months. (Expires the last day of the 24th month).
- IFR – the altimeter, encoder and static system has been inspected and certified within the past 24 months. (Expires the last day of the 24th month).



VOR Checks (FAR 91.171)

Every 30 days, the VORs must be checked by using either of the following methods:

- VOR test signal (VOT), allowable difference $\pm 4^\circ$.
- VOR ground check point, allowable difference $\pm 4^\circ$.
- Airborne VOR check, allowable difference $\pm 6^\circ$.

The locations and details for VOTs, ground and airborne VOR checkpoints, can be found in the **Chart Supplement** (formerly the Airport Facility Directory or A/FD).

- Dual VORs checked against one another. The allowable difference is $\pm 4^\circ$.
 - The VORs can be checked on the ground
 - The VORs can be checked in flight, but they must be checked using the bearing “to” the station method.
 - ✓ The VOR receivers must be independent, except for the antennae.

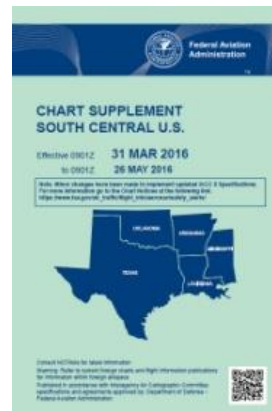

VOR ground check point

Additionally, you may have your VORs tested at a repair station. The VORs must be $\pm 4^\circ$ of the test signal and the repair station technician must make an **aircraft log** entry, certifying the check.

Log the date, place and bearing error. If you accomplish a dual VOR check, you should record both bearings to the VOR. To make it official, you should sign the log.

Date	Place	Method	Error	Signature
8-25-2016	DRK VOR	Dual VOR	#1 170°, #2 174°	Grant Canyon
8-26-2017	PRC	VOT	#1 3°, #2 1°	Don Patrol

(FAR 91.171)



Required Documents on Board: A-R-R-O-W (FAR 91.203, 91.9)

- **A**irworthiness certificate,
- **R**egistration certificate,
- **R**adio license, if traveling outside the USA, and for some commercial operations.
To order online, go to <http://wireless.fcc.gov/uls/index.htm?job=home>
- **O**perating limitations. (The Owner's Manual)
- **W**eight and balance data.

Required Personal Documents (FAR 61.3)

- A current plastic (credit card style) pilot certificate that includes an "English Proficient" endorsement.
 - The English endorsement is required for international flying
- An appropriate current medical
- A government issued photo ID (Driver's license, military ID, or passport).

Misplaced License

Request temporary authority to exercise certificate privileges at <https://www.faa.gov/>.



Sign into your account and

- Click on the **Licenses & Certificates** TAB.
 - Select "**Airman Online Services**".
- The FAA will send a temporary certificate via fax or e-mail. You can only request one temporary certificate within any six-month period.
- At <https://www.faa.gov/>, you can also request a **replacement** certificate.

Changed Address (FAR 61.60)

The FAA must be notified within **30 days** of an address change, otherwise you may not act as pilot in command. You can change your address, add “English Proficient”, or any other amendment to your status by logging on at <https://www.faa.gov/> and clicking on the **Licenses & Certificates** TAB.



You may also change your address through the mail.

IFR – Required Reports to Air Traffic Control: (Reference

AIM 5-3-2, FAR 91-183)

- Vacating an altitude.
- Reaching or leaving a holding fix.
- VFR on top altitude change.
- Missed approach with request for specific action.
- If TAS changes 10 knots or 5%, whichever is greater. (5% of 200 knots TAS is 10 knots).
- If Unable to maintain a 500 FPM climb.
- Passing a point that ATC has asked you to report.
- Safety of flight information.
- When encountering un-forecasted weather.
- Equipment malfunctions.
- Malfunctions of navigation, approach, or communication equipment, and the degree to which the malfunction affects the pilot's ability to operate under IFR in the ATC system. (Report the nature and extent of assistance needed from ATC).



IFR – Required ATC Reports when NOT in RADAR Contact:

- **Non-Precision Approach:** When leaving the FAF, inbound.
- **Precision Approach:** When leaving an outer marker (OM) or the OM substitute, Inbound.
- When the revised ETA is greater than three minutes.
- When the estimated arrival time over a designated reporting point is off by more than three minutes.
- When Passing designated reporting points.

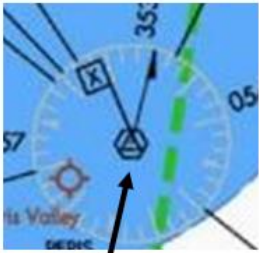

Not designated

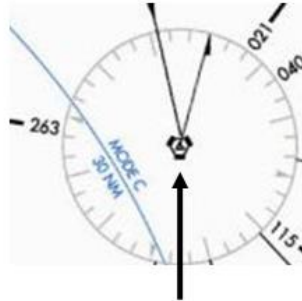

Designated



IFR Position Reports consist of:

- Call sign,
- Name of reporting point,
- Time over reporting point,
- Altitude,
- The fact that you are "IFR". You can omit this if reporting to an approach or center controller. (They know that you're IFR),
- Estimated time over the next **reporting point**,
- Name of the **reporting point** after the next reporting point.

Example: "Houston Center, N98X, over Junction at 2158, 10,000. Estimating Center Point at 2220. San Antonio next."

Mode C Transponder

An operating Mode C is required in:

- Class A airspace,
- Class B airspace, (within 30 nm of the primary Class B airport – the veil),
- In and above Class C airspace, and
- Anytime, when operating above 10,000 MSL, excluding the airspace below 2,500 AGL.



If your transponder fails in flight, ATC can grant you permission to continue to your destination, where you will get it fixed.

In a GPS World

When flying a direct route (not on established airways) and not in radar contact with ATC – report over each reporting point used in the flight plan to define the route of flight. Remember, a fix is required in each ATC sector.

When a fix or VOR is used in your flight plan to define your route, it becomes a compulsory reporting point, **even if it's not a designated (solid triangle) fix.**

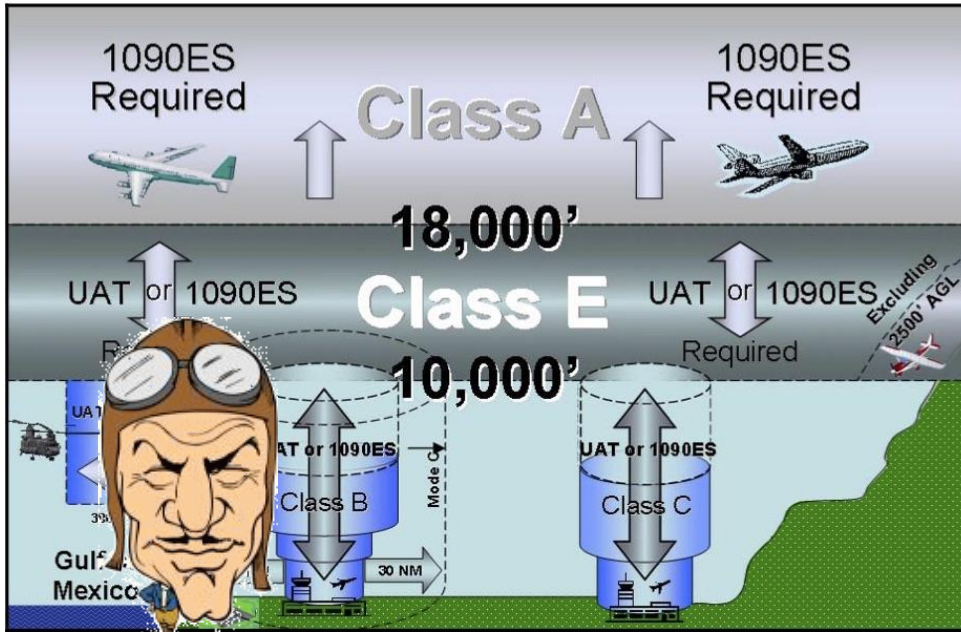

ADS-B Mandate: You will need to be ADS-B “Out” equipped when in ADS-B Mandate airspace, (shown at left).



***The controller told me, “Radar contact lost”,
but my transponder’s Reply Light is flashing.
Why?***

- Another radar – military or FAA, could be pinging the transponder, or
- The transponder may be responding to another aircraft’s *Traffic Alert and Collision Avoidance System (TCAS)* interrogation. (FAR 91.189)

Required Equipment, VFR DAY: **TOMATO FLAMES**

- **A**IRSPEED Indicator. (A1)
- **T**ACHOMETER, (for each engine). (T1)
- **O**IL PRESSURE gauge, (for each engine using a pressure system). (O1&2)
- **M**ANIFOLD PRESSURE gauge (M) for each altitude engine (A turbocharged reciprocating engine's manifold pressure is boosted and therefore, you must be able to monitor that pressure).
- **A**LTIMETER. (A2)
- **T**EMP gauge for each liquid cooled engine.
- **O**IL TEMP gauge (O1&2) for each air-cooled engine.
- **F**UEL gauge for each tank (F).
- **L**ANDING GEAR POSITION indicator, (if the aircraft has retractable gear). (L)
- **A**NTI-COLLISION LIGHT system (A3), if the aircraft was certified after March 11, 1996. (In the event of an Anti-collision light failure, you may continue to a location where repairs or replacement can be made).
- **M**AGNETIC DIRECTION INDICATOR (M2) (Installed in the aircraft).
- **E**LT (E) (FAR 91.207).
- **S**EAT BELTS (S). If the aircraft was certified after July 1978, you'll also need Shoulder Straps.

VFR Day Instrument Requirements



Tomato Flames



Required Equipment, VFR NIGHT: **FLAPS**

- **F**USES. If your aircraft is equipped with fuses, you'll need 3 of each kind, and they must be accessible in flight. Note: If your airplane has circuit breakers, there's no need to have fuses.
- **L**ANDING LIGHT – but only if you are flying for hire.
- **A**NTI-COLLISION LIGHT SYSTEM, if certified after August 11, 1971.
 - ✓ In the event of failure, you may continue to a location where repairs or replacement can be made.
- **P**OSITION LIGHTS. Must be on from sunset to sunrise. (Ref. FAR 91.209).
- **S**OURCE OF ELECTRICAL POWER (an alternator or generator).

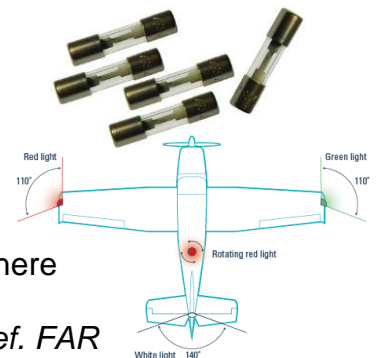

Required Equipment for an IFR Flight, in addition to the equipment required for VFR:

(FAR 91.205)

- **D**IRECTIONAL GYRO (DG) or equivalent.
- **R**ATE OF TURN indicator **or** an additional attitude indicator
- **A**TTITUDE INDICATOR.
- **G**ENERATOR or Alternator with adequate capacity.
- **S**KID / SLIP Indicator
- **C**LOCK installed in the aircraft, displaying hours, minutes and seconds.
- **A**LTIMETER.
- **R**ADIOS & NAV. Two-way radios and NAV equipment appropriate to the ground facilities to be used.



Travel Tip

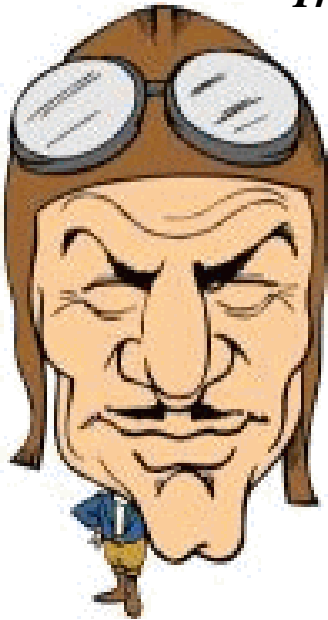

*You can take off with inoperative instruments or equipment that's not required by FAR 91, as long as that instrument or equipment is removed or placarded "**Inoperative**" and a pilot or mechanic determines that the loss of that instrument or equipment is not a hazard. The bad component or instrument must be unpowered/unwired.*

IFR Fuel Requirements (FAR 91.151 & 167)

- You will need enough fuel to fly to the destination and the alternate (if required) + enough fuel to fly for another 45 minutes at normal cruising speed.



Required Forecast Weather for a Legal Destination (FAR 91.167)

The destination weather must be forecast to be at or above that required for the planned approach.

CATEGORY	A	B	C	D
LNAV MDA	5040-1	509 (600-1)	5040-1½ 509 (600-1½)	NA
CIRCLING	5040-1	508 (600-1)	5040-1½ 508 (600-1½)	NA

You will need an Alternate IF:

- The destination doesn't have an instrument approach, **or**
- The destination doesn't meet the. . .

1-2-3 RULE

- ± 1 hour of your planned arrival
 - 2,000' ceiling
 - 3 miles visibility
- } Forecast Weather

The requirement to designate an alternate applies to pilots who are filing a flight plan. If airborne and the TAF or METAR improves above 2,000 & 3, your fuel planning could exclude the need for an alternate.



If your destination does not have a Terminal Area Forecast (TAF), use the [Graphic Area Forecast \(GFA\)](#). Use the "Ceiling/Visibility" tab and the ZULU time sliding bar to determine weather conditions at your arrival time.

Alternate Weather Requirements (FAR 91.167)

- Airports with a precision approach (ILS or PAR): Forecast to have **600 & 2 or more**.
- Airports with a non-precision approach – (no precision approach available): Forecast to have **800 & 2 or more**.

GPS World

*Although LNAV/VNAV and LPV approach minimums approximate ILS approach minimums, and Garmin refers to them as "precision approaches" with a Decision Altitude (DA), the FAA considers them to be **non-precision approaches**. Technically, they are classified as an Approach with Vertical Guidance (APV).*

Airports without an instrument approach can be used as an alternate if the forecast weather conditions are basic VFR from the Minimum Enroute Altitude (MEA) to the planned alternate airport.



GPS World **WAAS GPS Alternate Planning – Exceptions** (AIM 1-1-20)



Although LNAV/VNAV and LPV approach minimums approximate ILS approach minimums, they are still considered **non-precision approaches**, and are classified as an Approach with Vertical Guidance or APV. Therefore, if an alternate does not have a precision approach, such as an ILS or PAR, it must have, ± 1 hour of the ETA, a forecast of **800 & 2**.

When planning an alternate, WAAS GPS users can only consider the LNAV, circling, or Baro-VNAV (if so equipped) lines of minimums at the alternate airport. **If upon arrival at the alternate**, a VNAV or LPV approach is available, VNAV or LPV minimums may be used.

Non-WAAS GPS Approach & Alternate Planning



A Non-WAAS GPS is considered “supplemental” to navigation. If you’re flying airways, you must back everything up with the VOR.

- **Non-WAAS GPS users** may plan to use a GPS-based instrument approach at either their destination or alternate airport, but not at both locations.

The alternate must have an available approach procedure that does not require the use of GPS.

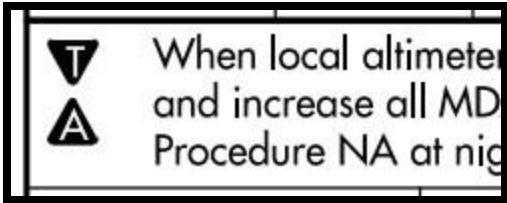

Special Alternate Minimums

This reverse A symbol indicates that special alternate minimums with restrictions are **ALTERNATE MINS** section of each U.S.

required. These are found in the Terminal Procedures Publication.

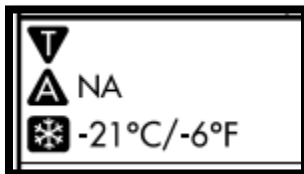

Alternate Not Applicable

This reverse A NA symbol means that you cannot use the airport as an alternate because either the facility's NAVAID(s) are unmonitored, the airport lacks a weather reporting service, or it lacks adequate navigation coverage.



IFR Operations to High Altitude Destinations and Alternates – Considerations (AIM 5-1-9)

Three high altitude airports in the U.S. have

approved instrument approach procedures where all of the MDAs are greater than 2,000 feet and/or the landing visibility minimums are greater than 3 miles. These are South Lake Tahoe, CA (KTVL), Bishop, CA (KBIH) and Aspen, CO (KASE).

It is possible for a pilot to elect to not carry sufficient fuel to continue to an alternate when the destination's forecast ceiling and/or visibility is actually lower than that necessary to complete the approach.

Also, a small number of mountain airports have MDAs that are just below 2,000 feet AGL. If the weather deteriorates slightly, the airport could be below minimums.

CATEGORY	A	B	C	D
RNAV MDA	6600-1¼ 2477 (2500-1¼)	6600-1½ 2477 (2500-1½)	6600-3 2477 (2500-3)	NA
CIRCLING	6600-1¼ 2476 (2500-1¼)	6600-1½ 2476 (2500-1½)	6600-3 2476 (2500-3)	NA

BISHOP (BIH)

37°22'N-118°22'W **RNAV (GPS) Y RWY 12**



Cold Temperature Restricted Airport

The “snow” symbol indicates that “**Cold Temperature Altitude Operation**” procedures are required when the temperature at this

airport is less than - 21°C / - 6°F. When flying this type of approach, you must advise ATC when an altitude correction is made in the intermediate and/or missed approach segment, **but not in the final approach segment**. The error table (shown below) can be found in the first few pages of the Terminal Procedures Publication. (Add the error value to your indicated altitude)



REPORTED TEMP °C	200	300	400	500	600	700	800	900	1000	1500	2000	3000	4000	5000
+10	10	10	10	10	20	20	20	20	20	30	40	60	80	90
0	20	20	30	30	40	40	50	50	60	90	120	170	230	280
-10	20	30	40	50	60	70	80	90	100	150	200	290	390	490
-20	30	50	60	70	90	100	120	130	140	210	280	420	570	710
-30	40	60	80	100	120	140	150	170	190	280	380	570	760	950
-40	50	80	100	120	150	170	190	220	240	360	480	720	970	1210
-50	60	90	120	150	180	210	240	270	300	450	590	890	1190	1500

EXAMPLE-

At -20 degrees Celsius, if your aircraft is 1,000 feet above the airport elevation, the reported current altimeter setting may place the aircraft as much as **140 feet below** the altitude indicated by the altimeter. At -25°C, you would interpolate a **165-foot** error.

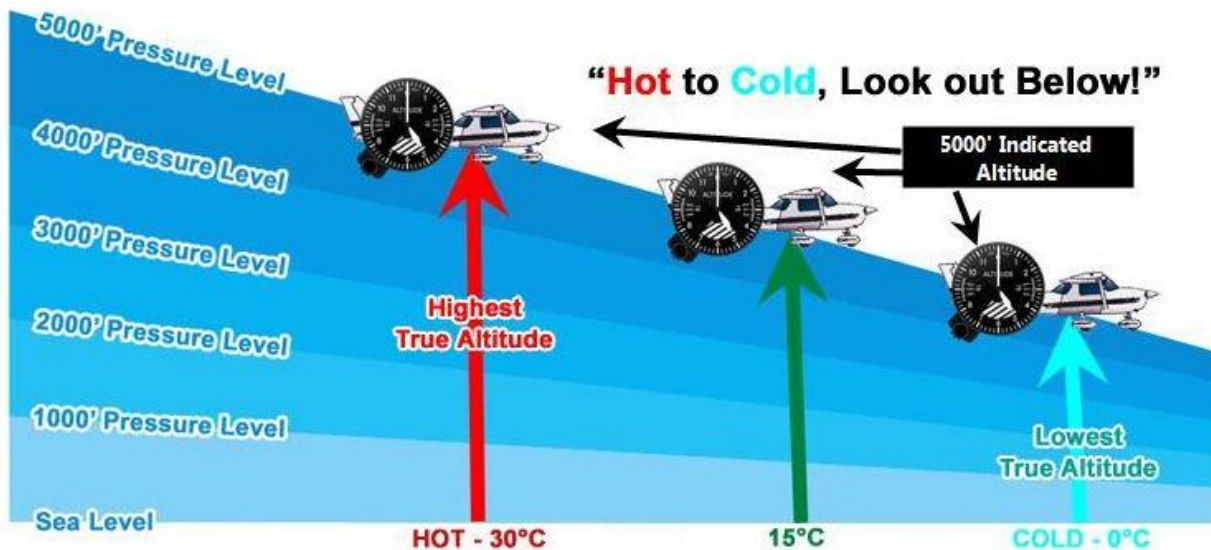

Avionics Failures and Approaches

If an airport has approaches that require special equipment, such as DME or a glide slope, and the aircraft's DME or glide slope fails enroute, you should consider that you may not be able to fly a successful approach.

When an Alternate Becomes Your Destination (AIM 1-1-20)

If the destination weather deteriorates, and you divert to your alternate, it's now your "destination" and the alternate weather requirements, (600 & 2, and 800 & 2), are replaced with the weather that is required to initiate the approach.

FL180 and Above – Class A Airspace

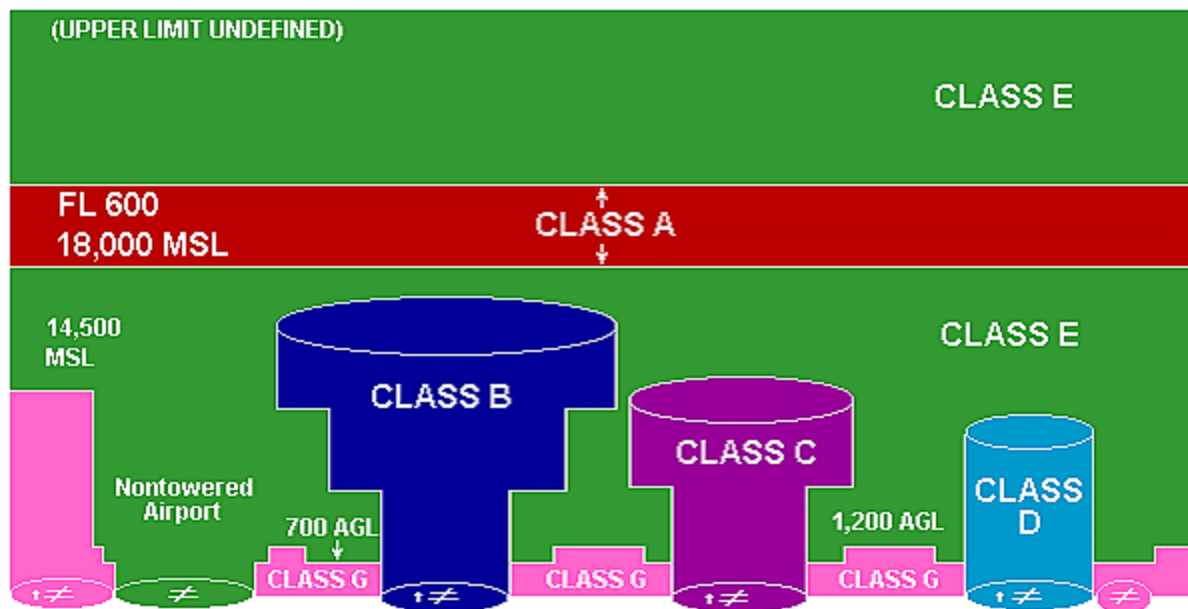

In Class A airspace:

- You must be on an IFR flight plan. (VFR on Top is NOT allowed).
- A 1090 MHz extended squitter (ES) transponder is required.
- You must set your altimeter to 29.92 when climbing through the transition level – usually 18,000 feet MSL.
- The assigned altitudes are called "Flight Levels". FL180, FL190, etc.
- Above FL240, DME is required.
- FL 180 is not usable when the altimeter setting is below 29.92, but higher than 28.92. If below 29.92, the lowest assignable flight level is FL190. (See FAR 91.121 for more information)

Charts and the ATC System

NAVAIDs

VOR STANDARD SERVICE VOLUME	ALTITUDE AND RANGE BOUNDARIES
T (Terminal)	From 1,000' AGL up to 12,000' AGL; RANGE: 25 nm radius
L (Low Altitude)	From 1,000' AGL up to 18,000' AGL; RANGE: 40 nm radius. Used only on Victor airways
H (High Altitude)	From 1,000' AGL to 14,500' AGL; RANGE: 40 nm radius From 14,500 AGL to 60,000'; RANGE: 100 nm radius Used on Victor airways and Jet routes.

Some Victor airways have MEAs that may seem to be too low for the VOR's service volume and altitude / range boundaries. However, these MEAs have been flight tested and proven to provide good VOR reception.

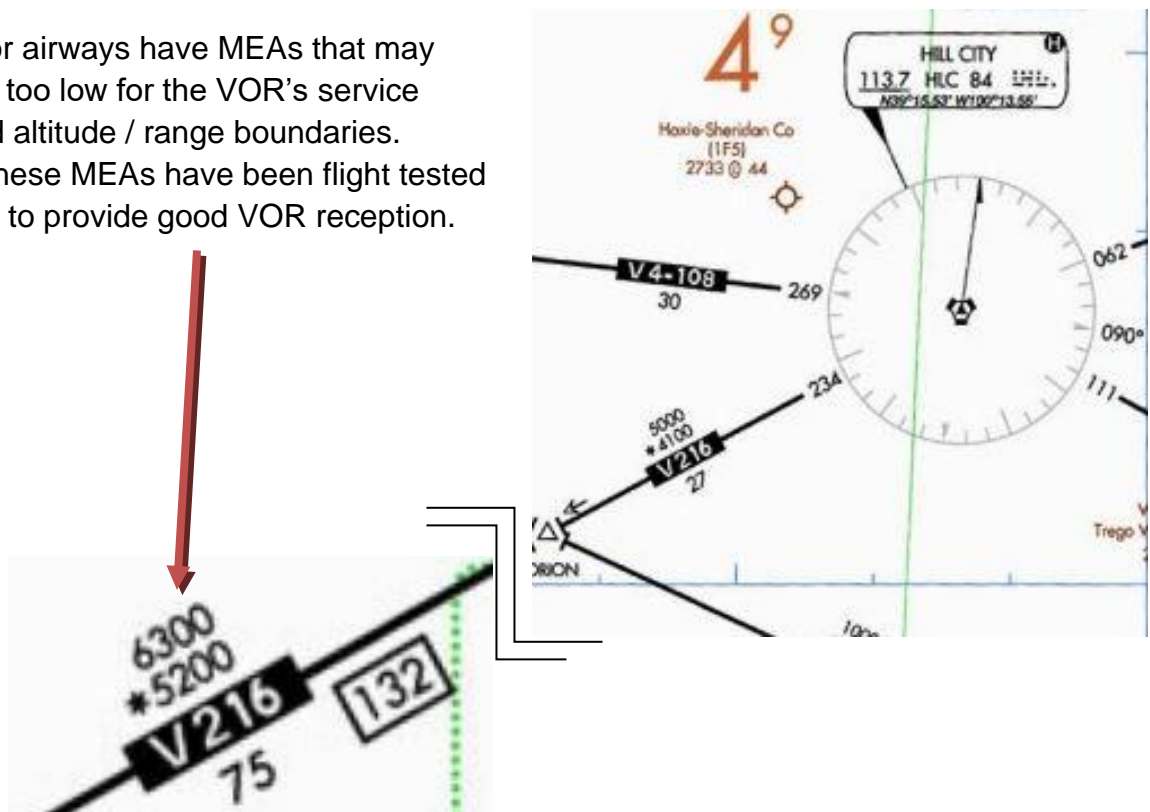

NDB SERVICE VOLUMES & CLASS

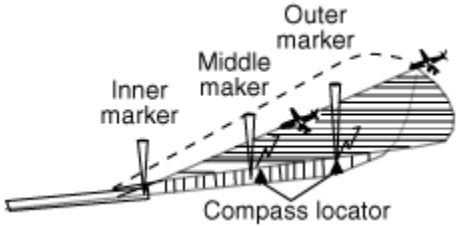
CLASS NDB	Wattage	Effective Range
Compass Locator 	Below 25	15 nm
MH	Below 5	25 nm
H	50 to 1,999	50 nm
HH	2,000+	75 nm

MARKER BEACONS

Type	Where one would encounter a marker beacon:
OM	Intercepting the ILS Glide slope
MM	.5 to .8 nm from the landing threshold (at 200' above the touchdown zone) CAT I Decision Height (DH)
IM	Located at runway threshold. Cat II and III Decision Height (DH)

(Reference AIM 1)

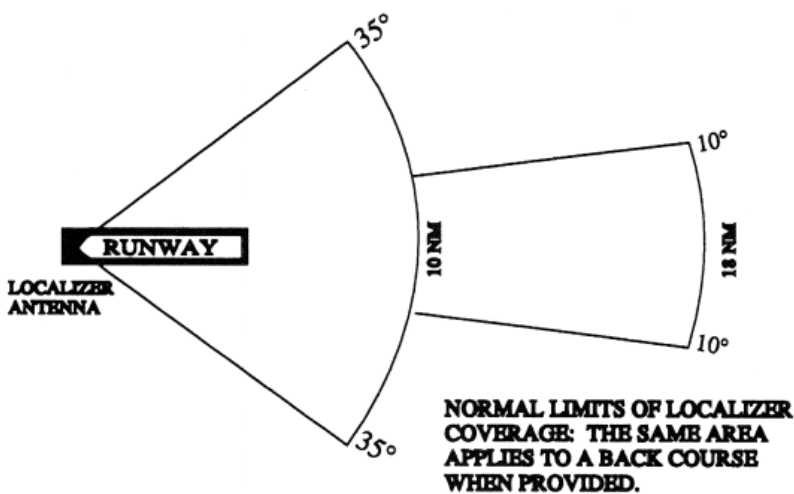

Localizer Coverage Limits / LOC BC & GS

Localizers offer course guidance up to 18 nm from the antenna.

ATC and the IFR Chart Review

Victor airways

- Class E airspace.
- 1,200 feet AGL to 18,000 feet MSL.
- Generally, the width is 4 nm either side of the airway, expanding to 4.5 nm, 102+ nm from each VOR.

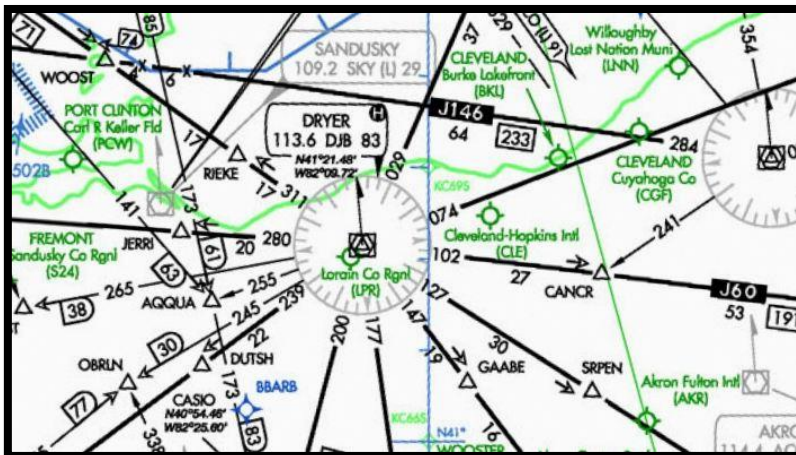
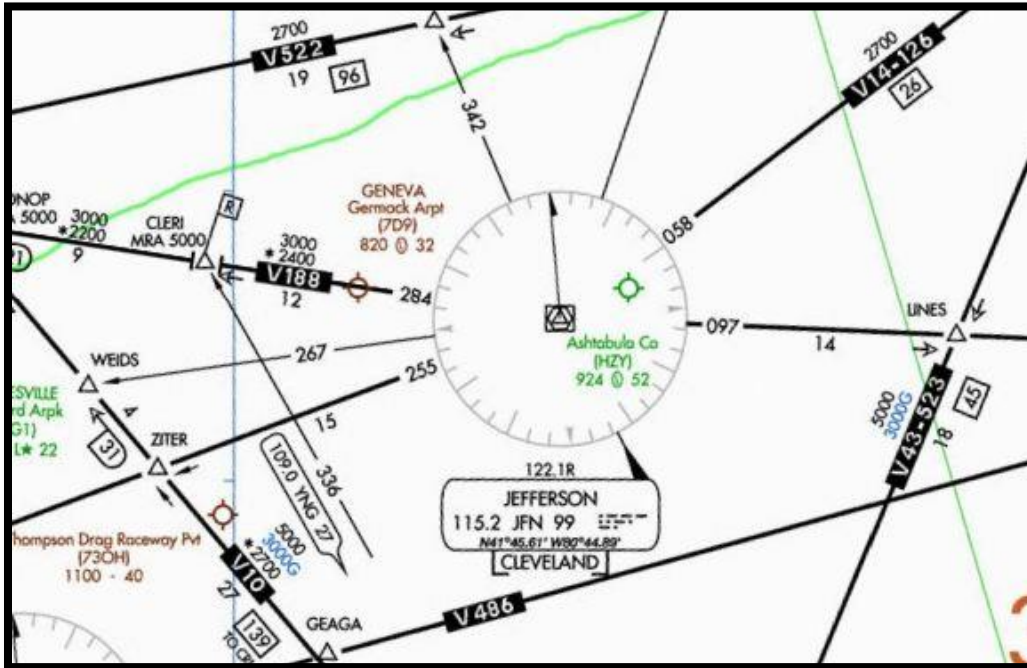

Jet routes – 18,000 feet MSL to 45,000 feet MSL. **Above 45,000 feet**, aircraft use GPS or other navigational systems to fly their own points – direct, and off the airways.

Colored routes



These are NDB radials with color prefixes – “Red”, Green”, “Amber”, and “Blue”, followed by a number, such as R4, G16, A7, B2, etc.

These are found along the Carolina coastal waters, and in Alaska. (2020 – Currently, the FAA has proposed that the colored routes be eliminated)

GPS/RNAV Airways

- Depicted in blue
- “T” prefix on the Lo Charts
- “Q” prefix on the Hi Charts



“T” or “Tango” routes

- “Terminal” routes exist below the ARTCC airspace (Class A).
- Used by RNAV equipped aircraft from 1,200 feet above the surface, (or in some instances higher), and up to but not including 18,000 feet MSL.

“Q” – routes

- Depicted on enroute **High** Altitude Charts
- Used by RNAV equipped aircraft between 18,000 feet MSL and FL 450 inclusive.

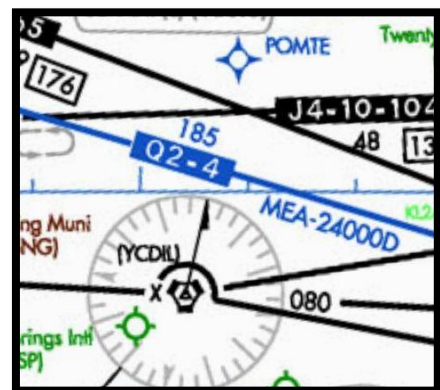

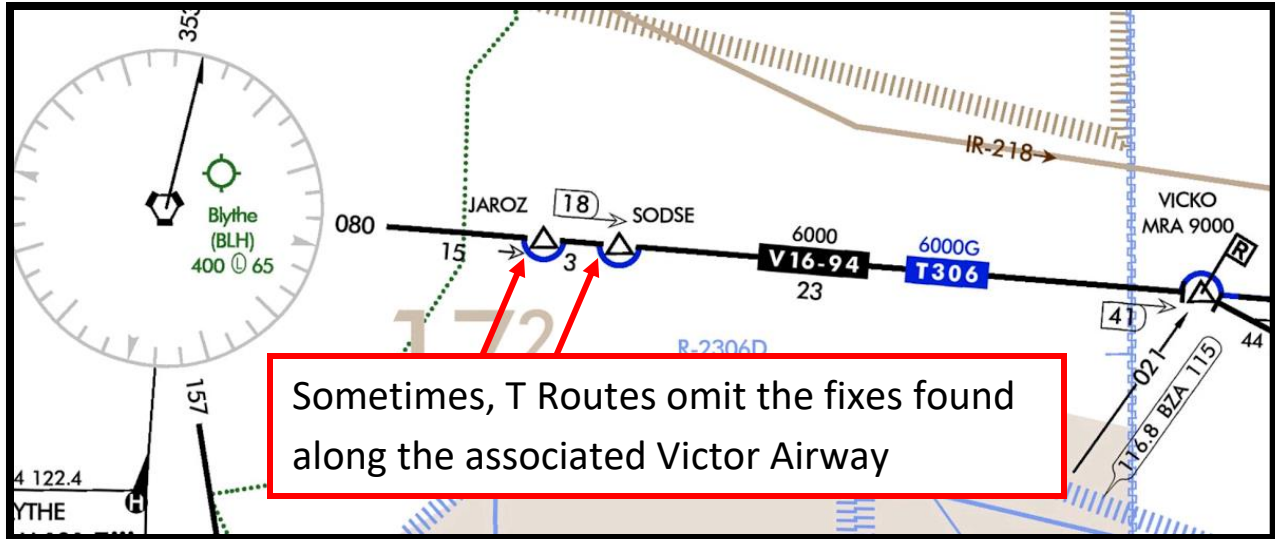

MEA – Minimum En route Altitude –



- Assures acceptable navigational signal coverage
- Meets obstacle clearance requirements between VORs
 - 1,000 feet or greater clearance in non-mountainous areas
 - Greater than 2,000 feet clearance in mountainous areas.

NOTE: The Fort Smith VOR frequency, 110.4 is underlined because it does not have voice capability.



suffix.



OROCA

Off Route Obstruction
Clearance Altitude

- Found in each quadrangle of an IFR Chart,
- Considers a 1,000-foot obstacle clearance in non-mountainous terrain
- Considers a 2,000-foot

obstacle clearance in mountainous terrain.

- Used for off-airway navigation.

If you are flying at the OROCA, you may not:

- Be able to receive ground-based NAVAID signals,
- Be high enough to be seen by air traffic control radar,
- Be able to communicate with air traffic control.



It is far better to arrive late in this world, than early in the next.

CHICAGO, ILLINOIS		
LOC I-RXZ 111.3	APP CRS 223°	R T A
Simultaneous a LOC procedure #DME from OR		
ATIS 135.4 282.225	CHICAGO APP 119.0 393	
MSA ORD 25 NM 3400		

MSA – Minimum Safe Altitude

- Found on approach plates.
- Provides 1,000 feet obstacle clearance for emergency use within a specified distance from the listed navigation facility.
- MSA is normally based on the primary NAVAID on which the approach is predicated.
- RNAV approach MSAs are based on the runway waypoint (RWY WP) for straight-in approaches, or the airport waypoint (APT WP) for circling approaches. For GPS approaches, the MSA center will be the missed approach waypoint (MAWP).

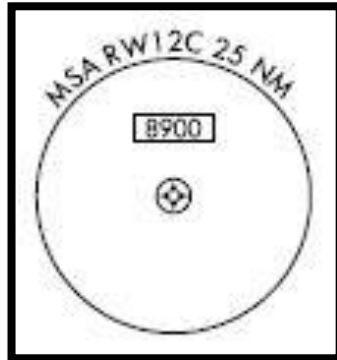

Rwy Based MSA

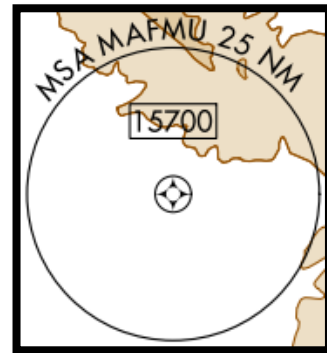

Missed Approach Point MSA

MAA – Maximum Authorized Altitudes

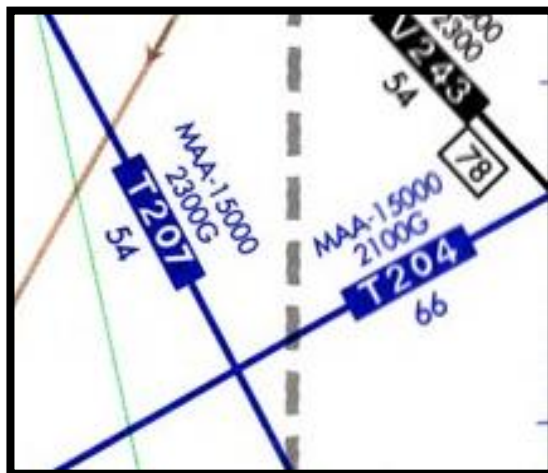

- Above the MAA, it could be possible to tune in a faraway station that has the same frequency but has nothing to do with the airway.

GPS World

GPS routes like T207 and T204, (shown here), do not involve VORs, but an MAA is most likely depicted because a higher altitude may interfere with the controlling Center's airspace.

MCA – Minimum Crossing Altitude



A fix or NAVAID that must be crossed at or above a specified altitude. This one requires that when southbound on V269, you cross SPATS at 13,000 feet MSL.

MRA – Minimum Reception Altitude

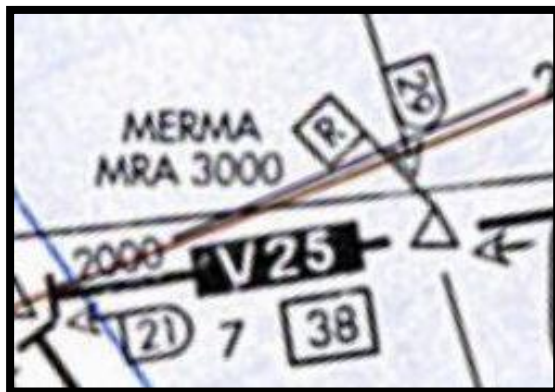

- Lowest altitude at which an intersection can be determined with two VORs.
- Provides terrain clearance.
- The MRA at MERMA is 3,000 feet MSL.

COP – Change Over Point

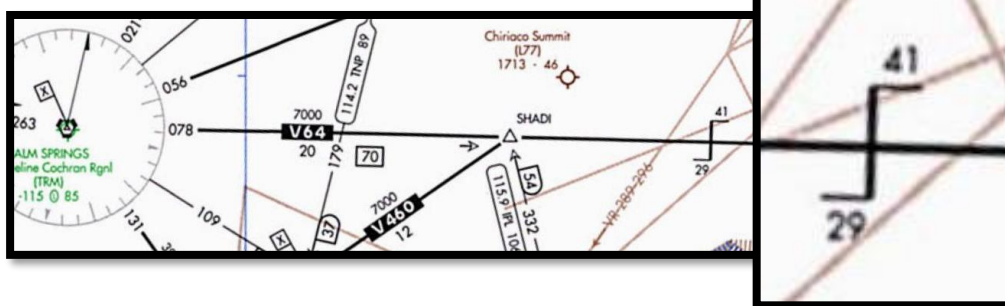

The DME point at which you must switch from one VOR to another.

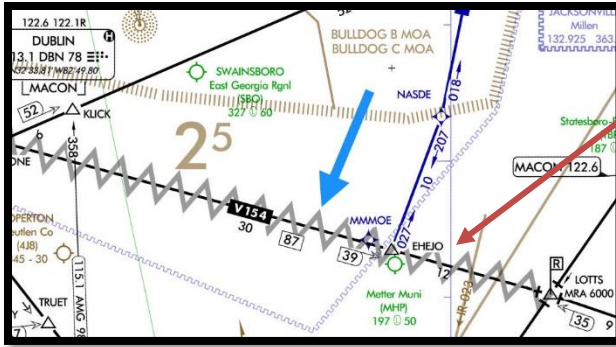

An unusable airway

This portion of V154 is unusable

MOCA – Minimum Obstacle Clearance Altitudes

- Jeppesen depicts a MOCA with an altitude followed by a “T”, such as **3800T**.
- AeroNav charts depict a MOCA with an asterisk followed by the altitude, such as ***3800**.
- MOCA provides terrain clearance and NAVAID reception within 22 nautical miles of the NAVAID.
- If both an MEA and MOCA are listed on the airway, the pilot can fly as low as the MOCA, (with ATC clearance, of course), if he or she is within 22 nm of the VOR concerned. (FAR 91.177)



Cherokee is a VOR with DME and it's also a compulsory reporting point, should ATC surveillance be unavailable. 115.0 is underlined, meaning that voice is not available on this VOR. However, 122.4, (above the box) is an RCO and Flight Service can transmit and receive on that frequency.

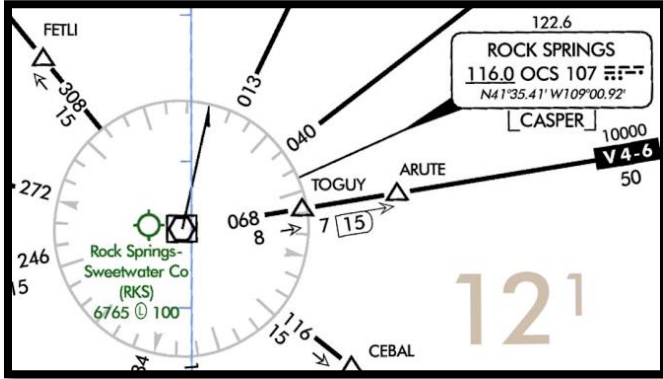

Rock Springs is a VOR with DME, but should ATC surveillance be unavailable, OCS is not a compulsory reporting point. 116.0 is underlined, meaning that voice is not available on this VOR. However, 122.6, (above the box) is an RCO and Flight Service can transmit and receive on that frequency.

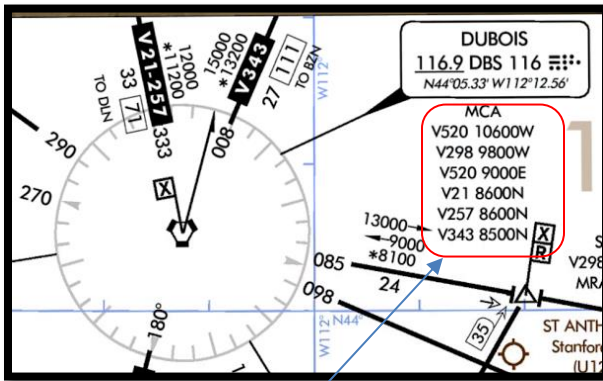

Dubois is a VORTAC (both a VOR and TACAN). This VORTAC symbol is not black in the center, indicating that should ATC surveillance be unavailable, it is not a compulsory reporting point. VORTACs always have DME. 116.9 is underlined, meaning that the VOR does not have voice capability. Note: A plain old TACAN, (without a VOR), never has voice capability.

Note the numerous Minimum Crossing Altitudes (MCAs) listed for Dubois.

Minimum Vectoring Altitude (MVA) is the lowest MSL altitude at which an IFR aircraft will be vectored by a radar controller. The minimum vectoring altitudes for radar approaches, departures, and missed approaches could be lower.

MVAs meet IFR obstacle-clearance criteria –

- *Non-Mountainous Areas:* 1,000 feet above the highest obstacle.
- *Mountainous Areas:* 2,000 feet above the highest obstacle.
 - 1,000-foot clearance above the highest obstacle may be authorized with the use of Airport Surveillance Radar (ASR).

The MVA may be lower than the published MEA along an airway or jet-route segment and can be used for radar vectoring if the controller has an adequate radar return.

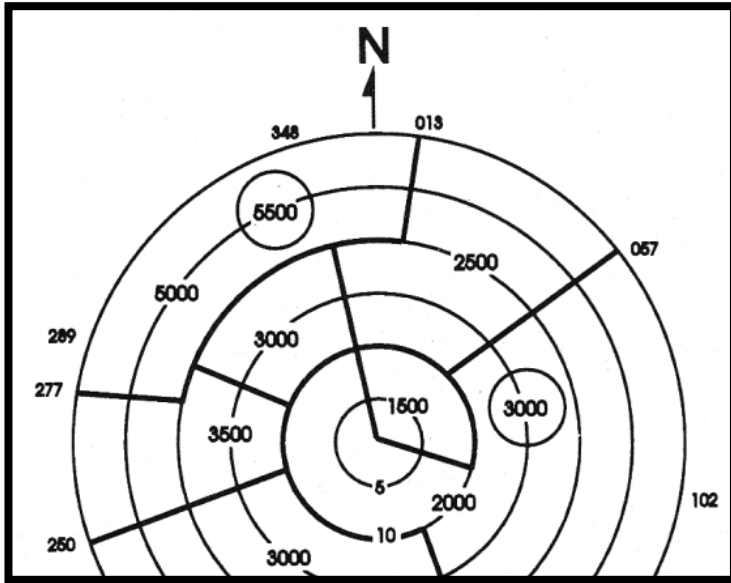

Charts depicting MVAs are available only for the controllers.

MVAs and Terrain Clearance Responsibility

If a controller makes a mistake and vectors you into terrain, he might bear some responsibility, but you are still dead. *Maintain situational awareness by:*

- Using the VFR Charts and all available NAVAIDs to crosscheck terrain clearance altitudes.
- Asking the controller if you are in doubt.
- Utilizing and respecting Ground Proximity Warning / Terrain Warning, should you have it.

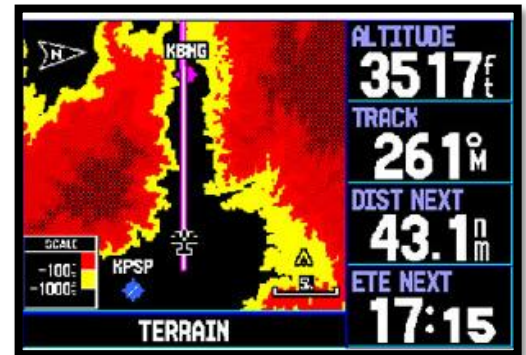

Flight Planning – RNAV / GPS Direct

- Avoid all sensitive areas such as TFRs, Restricted, and Prohibited areas.
- Your route should include one “real fix” – a fix that ATC will recognize – in each ARTCC area.
- ATC requires radar coverage and monitoring for a direct flight.

Unpublished RNAV Routes are direct routes based on area navigation / GPS capability between waypoints defined by:

- Latitude/longitude, *or*
- Degree-distance fixes, *or*
- Offsets from established airways at a specified distance and direction.

All unpublished RNAV routes require ATC radar monitoring.

ATC's Preferred IFR Routes are found in the **Chart Supplement** (formerly the Airport Facility Directory or A/FD) and are divided into low and high-altitude routes. These can be one way or two-way routes. **Preferred IFR routes beginning with a fix, indicate that departing aircraft will normally be routed to the fix by an Instrument Departure Procedure (DP), or radar vectors.**



NOTAMs and Before Takeoff Planning

NOTAMs

The FAA's NOTAM search site is at notams.aim.faa.gov/notamSearch. It has a fully optimized, interface search tool with digital NOTAMs, this site provides a one-stop shop that lets you customize your NOTAM search. You can use criteria such as time and date, location, flight path, geographic area, latitude/longitude, keywords, and more. You can filter and sort results by location, class, start and end date, condition, and (again) more. You'll also find Letters to Airmen and a link to Airport Construction Notices in pdf format.

Location	Number	Class	Start Date UTC	End Date UTC	Condition
DCA	N/A	Aerodrome	09/11/2019 2230	PERM	ON AIRPORT - SEE CONSTRUCTION GRAPHIC
DCA	02/264	Communi...	02/20/2020 1100	PERM	COM COM FALLS CHURCH REMOTE COM OUTLET 122.2 U/S 2002201100-PERM
DCA	12/042	Aerodrome	12/03/2017 2049	PERM	TWY N BTN APCH END RWY 15 AND TWY K CLSD TO ACFT WINGSPAN MORE THAN 124FT 1712032049-PERM
OTT	05/168	Navaid	05/10/2019 1845	PERM	NAV VOR OUT OF SERVICE 1905101845-PERM
DCA	06/265	Communi...	06/20/2019 0001	PERM	COM REMOTE TRANS/REC 319.1 CHANGED TO 239.25 1906200001-PERM
DCA	06/266	Communi...	06/20/2019 0001	PERM	COM REMOTE TRANS/REC 269.0 CHANGED TO 360.8 1906200001-PERM
DCA	08/182	Obstruction	08/15/2019 1000	PERM	OBST BLDG LGT (ASN 2018-AEA-6441-OE) 385213N0770235W (1.2NM NNW DCA) 78FT (67FT AGL) U/S 1908151000-PERM
DCA	01/185	Airspace	01/15/2020 0008	PERM	AIRSPACE SEE FDC 1/1155, 9/1811, 0/0053, 9/1812, 0/3929 ZDC SPECIAL SECURITY INSTRUCTIONS 2001150002-PERM 2001150008-PERM
DCA	02/248	Obstruction	02/18/2020 1653	09/30/2022 2359	OBST CRANE LGT (ASN 2019-AEA-1836-OE) 385529N0771242W (9.1NM WNW DCA) 891FT (606FT AGL) U/S 2002181653-2209302359

TFRs

Since TFRs are the subject of many NOTAMs, another FAA website resource is tfr.faa.gov. TFRs can pop up quickly and violating one because you didn't feel like

checking NOTAMs isn't a winning excuse. The website gets updated in real time, so it provides the most current information on published TFRs nationwide. Please do note that the site includes a disclaimer that when planning a flight, always call 1-800-WX-BRIEF for a more complete listing. Select the state where you're operating or expect to fly. Click the hyperlink under the NOTAM column for details and graphical representation on the time, date, and altitude of effectiveness. The "other information" section names the controlling agency and provides contact details.

Date	NOTAM	Facility	State	Type	Description	Zoom
11/21/2020	0/4528	ZSE	WA	HAZARDS	BELLINGHAM, WA, Sunday, November 22, 2020 through Sunday, December 06, 2020 UTC	
11/21/2020	0/4527	ZSE	WA	HAZARDS	BELLINGHAM, WA, Sunday, November 22, 2020 through Sunday, December 06, 2020 UTC	
11/20/2020	0/4337	ZJX	FL	SPACE OPERATIONS	CAPE CANAVERAL, FL, Tuesday, November 24, 2020 UTC	+
11/20/2020	0/4336	ZMA	FL	SPACE OPERATIONS	CAPE CANAVERAL, FL, Tuesday, November 24, 2020 UTC	+
11/20/2020	0/4332	ZAN	AK	SPACE OPERATIONS	KODIAK, AK, Monday, December 07, 2020 through Friday, December 18, 2020 UTC	
11/20/2020	0/3916	ZAB	TX	SECURITY	Van Horn, TX, Sunday, November 22, 2020 through Sunday, November 29, 2020 Local	+

The Flight Service Pilot Web portal

The Flight Service Pilot Web portal at www.1800wxbrief.com is another online tool for quick and easy NOTAM searches. A free account enables you to get online preflight briefings, file flight plans, and get automatic notifications and alerts that include flight plan closure reminders, NOTAMs and TFRs, notices of new or adverse weather conditions, or pertinent airport closures. If you want someone to verbally translate NOTAMs, you can call Flight Service at 1-800-WX-BRIEF.

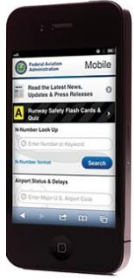

You can also find NOTAMs and TFRs on-the-go with FAA Mobile.

Third Party apps

Last but certainly not least, third-party providers in the aviation community, such as ForeFlight, Garmin Pilot, FlyQ, and Fltplan.com have done a lot to take the pain out of finding and reading NOTAMs. Most of the popular flight planning and flight management apps fish out the NOTAMs relevant to your specific flight plan. They also make it easier to read the information by lowering the shrill volume of ALL CAPS to sentence case.



GPS World

Predicting GPS RAIM, **Non-WAAS GPS**

Non-WAAS GPS users must confirm GPS RAIM availability **prior to an IFR flight**. Checking <http://sapt.faa.gov/default.php> satisfies this requirement.

FltPlan.com automatically checks RAIM for you.



GPS World

Wide Area Augmentation System (**WAAS**)

NOTAMs

GPS NOTAMs can also be located online at <https://notams.aim.faa.gov/notamSearch/>

Filters 6 | Sort | Count 14

Quick text filter:

Keyword(s): All None

- SVC
- TWY
- Airspace(3)
- Chart
- Communication(2)
- GPS

Include RNAV NOTAMs

	Date (in UTC)	Hr	Min
Start	yyyy-MM-dd	0	0
End	yyyy-MM-dd	23	59

Apply Clear Help

Enter a location. Then, using the “NOTAM filter” menu, select “GPS”

SAMPLE WAAS NOTAM:

!BOS BOS WAAS LPV AND LNAV/VNAV MNM UNREL WEF 0305231700—0305231815.

In a WAAS NOTAM, the term “UNREL” means that the expected level of WAAS service may not be available.

WAAS NOTAMs are Predictive and things could change. For instance, consider this sample WAAS NOTAM:
!BOS BOS WAAS LPV AND LNAV/VNAV MNM UNREL WEF 0305231700—0305231815.

If upon arrival in BOS, the LNAV/VNAV or LPV service is available, (annunciated as such on the GPS), then vertical guidance to LNAV/VNAV or LPV minimums **is allowed**.

If a WAAS NOTAM has not been included in the ATIS broadcast, controllers are required to tell pilots about the NOTAM as they clear the pilot for an RNAV (GPS) approach.



WAAS Vertical Guidance outage may occur daily and not be available and WAAS NOTAM service is not available.

MARATHON, FLORIDA		AL-6394 (FAA)	17061
WAAS CH 99605 W07A	APP CRS 071°	Rwy Idg 5008 TDZE 5 Apt Elev 5	RNAV (GPS) RWY 7 THE FLORIDA KEYS MARATHON INTL (MTH)
<p>Baro-VNAV NA when using Key West Intl altimeter setting. For uncompensated Baro-VNAV systems, LNAV/VNAV NA below -15°C (5°F) or above 49°C (120°F). DME/DME RNP-0.3 NA. Helicopter visibility reduction below 3/4 SM NA. When local altimeter setting not received, use Key West Intl altimeter setting and increase all DAs 93 feet, increase all MDAs 100 feet, increase LPV and LNAV/VNAV all Cats visibility 1/2 mile, LNAV Cats C and D visibility 1/2 mile, and Circling Cat C visibility 1/2 mile, Circling Cat D visibility 1/4 mile.</p>			MISSED APPROACH: Climb to 2000 direct LOGEY and hold.
ASOS 135.525	MIAMI CENTER 133.5 306.9	UNICOM 122.8 (CTAF)	

At these airports, whether it is your destination or alternate, plan for no lower than LNAV approach minimums.



Upon arrival, if WAAS GPS annunciations indicate that LNAV/VNAV or LPV is available, you may use the applicable lower WAAS minimums. However, be prepared to revert to the higher “LNAV” minimums if a WAAS vertical outage occurs.

An area-wide loss or malfunction of the WAAS system would be indicated by the phrase “**WAAS NOT AVBL.**”



Sample NOTAM for GPS Interference Testing at ZLA LOS ANGELES (ARTCC) PALMDALE, CA:

!GPS 04/050 (KZLA A0965/17) ZLA NAV (NTTR GPS 17-04) GPS (INCLUDING WAAS, GBAS, AND ADS-B) MAY NOT BE AVBL WI A 535NM RADIUS CENTERED AT 371957N1160221W (BTY033047) FL400-UNL, 488NM RADIUS AT FL250, 450NM RADIUS AT 10000FT, 403NM RADIUS AT 4000FT AGL, **378NM RADIUS AT 50FT AGL**. 1704161830-1704162230

This NOTAM sounds terrible and you wonder, “how am I going to receive the necessary GPS signals flying through that area?” Actually, the biggest threat is an area with a 378 nm radius. However, in this area, you would need to be cruising at 50 feet AGL and below to be affected. There are also small bands affecting aircraft at 4,000 feet AGL and 10,000 feet AGL. (See the graphic, next page)

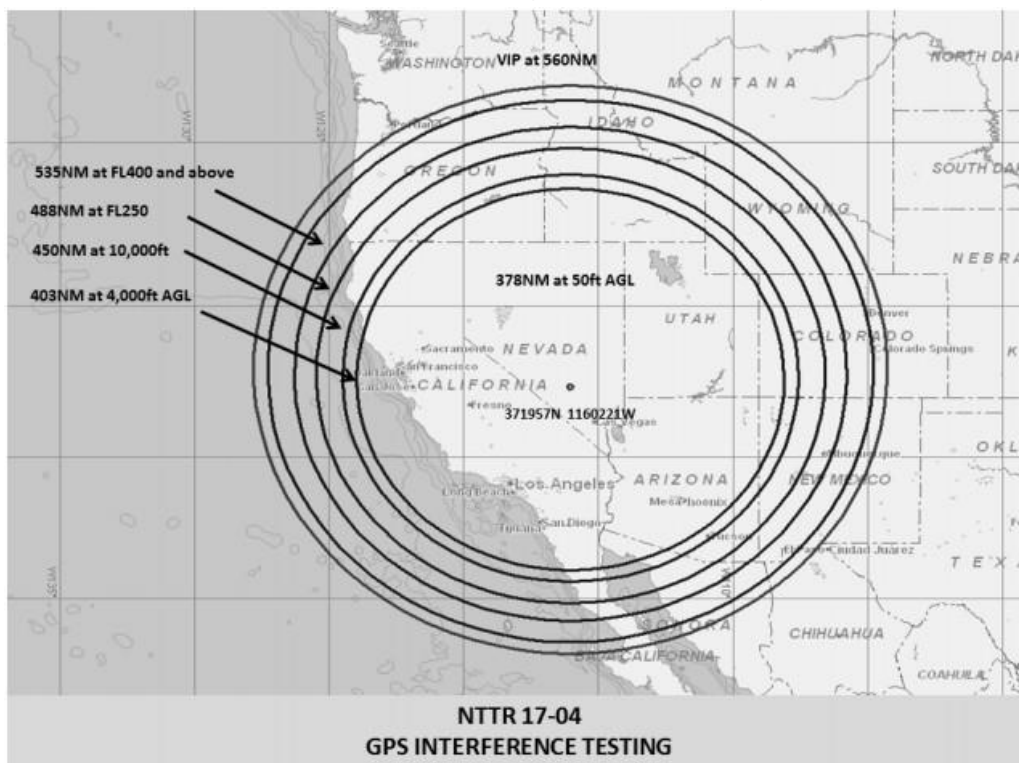

Why does the military introduce GPS interference testing? GPS is great, but the military never wants to rely entirely on GPS in time of war. These exercises are held to test their ability to operate should GPS become unavailable.

IFR Proposed Departure Time

Your clearance is good for only one hour after the scheduled departure time. You can ask Clearance Delivery to update your departure time. At non-towered airports, you can notify FSS of your **revised departure time**.

If ATC doesn't have your clearance, and you have filed using FltPlan.com, call their Clearance Hotline (staffed 24/7). The number appears on the upper right side of your NavLog. They'll check on the issue and correct it; refilling if necessary.

As of June 20, 2019, Flight service no longer relays IFR clearances. Exceptions are: MedEvac flights and clearances in remote Alaska areas.

The June 20, 2019 issue of the US Chart Supplement included a new batch of air traffic control facility phone numbers that pilots can call to receive or cancel IFR clearances. The FAA is not currently publishing a phone number if the airport has a frequency located on the field for pilots to contact either the tower, approach control, air route traffic control.



Flight Service will continue to accept phoned IFR flight plan cancellations in places or at times when it is not possible to call ATC on the radio before takeoff or after landing.

POLACCA (P10) 3 SW UTC-7 N35°47.50' W110°25.40'
5573 TPA—6398(825) NOTAM FILE PRC
RWY 04-22: H4200X50 (ASPH) RWY LGTS(NSTD) 0.3% up NE
RWY 04: Brush.
RWY 22: Brush.

SERVICE: LGT Rwy 04-22 LIRL solar powered lighting system.

AIRPORT REMARKS: Unattended. Rwy 04-22 has numerous large cracks, holes, rough surface, patches and loose rock. Rocks piled, in circle, around wind indicator. Rwy 04-22, 1-5' brush 45' from centerline both sides full length of rwy. Road crossing rwy. Wash in safety zone. This apt underlies a Military Operations Area (MOA). Pilots need to be aware of all restrictions and check for any NOTAMS in advance of flying through the MOA. Solar powered blue perimeter lgts at corners of parking ramp.

AIRPORT MANAGER: (928) 734-3243

COMMUNICATIONS: CTAF 122.9

CLEARANCE DELIVERY PHONE: For CD ctc Denver ARTCC at 303-651-4257. 

RADIO AIDS TO NAVIGATION: NOTAM FILE PRC.

TUBA CITY (H) VORTAC 113.5 TBC Chan 82 N36°07.28' W111°16.18' 100° 45.7 NM to fld. 5045/15E.



DENVER
L-8G

Beginning October 2019, the chart supplement will also include backup clearance delivery phone numbers for all airports with an RCO, GCO, or remote transmitter/receiver, in case published radio communications become unavailable.

Leidos, the FAA's flight service contractor, can also provide pilots with the name and phone number of the facility to contact.

Void Time

If you do not depart by the void time specified in your clearance, you must notify ATC as soon as possible, but not more than 30 minutes after the void time. ATC will initiate search and rescue procedures 30 minutes after your void time.

GPS World *GPS Preflight*

At “boot up”, verify that you have a current GPS database.



Before Takeoff Checks

- VORs – Check.
- The Altimeter should read ± 75 feet of field elevation.
- VSI – Indicates zero. If not, note the error.
- Attitude Indicator – Set.
- Heading Indicator – Set before taxi.



Travel Tip

After starting the engine, the gyro driven attitude and heading indicators may not reach operating speed for five minutes.

Taxi Check

- Check the brakes
- Ensure that the turn coordinator indicates turns and the ball moves to the outside of the turns.

IFR Clearance

Controllers will always give your clearance in the same sequence:

- **C**learance limit,
- **R**oute,
- **A**ltitude,
- **F**requency (Departure),
- **T**ransponder Code



When the Clearance Delivery Person has had too Much Caffeine

Have you ever tried to copy an IFR clearance and the controller is talking much faster than you can listen and write? Well, forget about what you missed and just continue to write. Perhaps you missed the route, but you can write down the altitude, departure frequency and the squawk code.

You now have most of the clearance, and you could then read back, “Cessna 123XZ is cleared to San Antonio via direct EDWAR, **rest of the route missing**, climb and maintain 4,000, expect 10,000, ten minutes after departure, departure frequency . . .”, and so forth.

The controller can now reply with, “The rest of the route from EDWAR is Victor 68, Junction, V198, San Antonio.”

That saves a lot of time and un-clutters the frequency. So, **do not focus on what you missed**. Let go of it, and just keep writing.

Takeoff & Departure

1 or 2 ENGINE AIRCRAFT	3 OR MORE ENGINES
1 SM Visibility	½ SM Visibility



On an *AeroNav* approach chart, (formerly *NACO*), the triangle T symbol indicates **the airport has published IFR takeoff minimums, and or departure procedures in Section L.**



charts provide the Part 135 takeoff minimums on the **runway diagram** page.

AeroNav Takeoff Minimums are specified in the Terminal Procedures Publication in this area (section L).



For Example:

WENDOVER, UT (KENV)

TAKEOFF MINIMUMS AND (OBSTACLE) DEPARTURE PROCEDURES

AMD 7 16091 (FAA)

TAKEOFF MINIMUMS: **Rwy 26**, std, w/min. climb of 300' per NM to 5900. **Rwy 30**, NA – ATC.

If you are in a one or two engine aircraft, you can take off with 1 SM visibility, but only if you can sustain a climb gradient of 300' per NM to 5,900 MSL.

That might seem easy since the field elevation is 4,237'.

However, before you blast off, you should check the required FPM for a 3.0 Climb/Descent Angle using the CLIMB/DESCENT TABLE on the last page of the Terminal Procedures Publication.



Part 91 IFR Takeoff Minimums

None - If you have not been assigned a SID, then you can legally depart in zero-zero conditions – but legal does not mean “**smart**”!

IF YOU HAVE BEEN ASSIGNED A SID, you are now under contract to observe the takeoff weather minimums associated with that SID. **Look at the TAKEOFF MINIMUMS** for San Diego’s PEBLE SIX DEPARTURE, (next page).

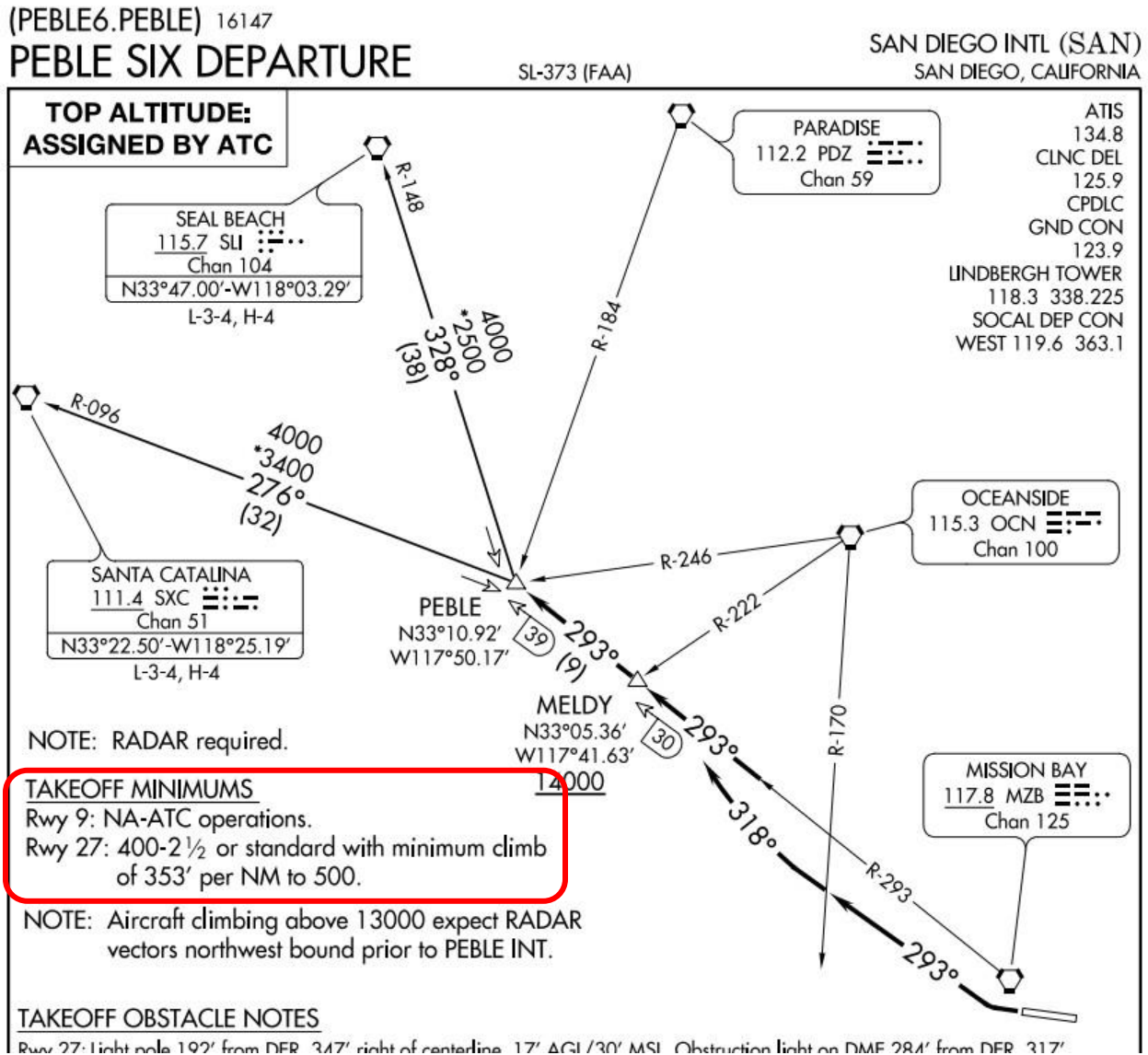



Travel Tip

Do not depart unless the airport's weather is at or above landing minimums.

If you must depart in weather that is below landing minimums, select a nearby "takeoff alternate" with VFR or alternate weather minimums. If you experience a problem, you will have a viable place to land.

What does the Takeoff Clearance, "Fly Runway Heading" mean? (Reference the Pilot/Controller Glossary)

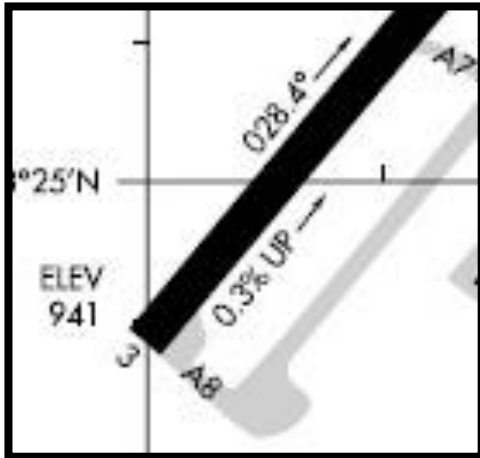

When cleared for takeoff, and directed to "fly runway heading," pilots are expected to maintain the heading that corresponds with the extended centerline of the departure runway. For example, referencing the KGYR Airport Diagram, Runway 03 has an actual magnetic heading of 028.4° – That is the runway heading, and it's flown from liftoff. **Drift correction shall not be applied.**

Obstacle Departure Procedures (ODP)

ODPs are one of the best kept "non-secrets" in flying. They often are difficult to find and almost never assigned by ATC, so it is understandable that many pilots have a hazy understanding of ODPs. Do not assume that "cleared as filed" or "cleared direct to" a fix means that you will be clear of terrain and/or obstacles without using the ODP.

- Regulations don't require the use of an ODP, and the *Controller Handbook* indicates that it's up to the pilot.
- You don't need a clearance to fly an ODP, but at a non-towered airport, ATC assumes that you'll use one.
- If the ODP is graphical and included in your clearance, then you must fly it.
- The pilot is responsible for terrain clearance until ATC issues a radar vector or clears the aircraft from the ODP.
- The pilots of multi-engine aircraft must consider the effect of degraded climb performance and actions to take in the event of an engine loss.
- At unfamiliar airports, one should follow the ODP in IMC or at night.

- Airports that don't have an instrument approach, (and a few that do), don't have an ODP.
- If the ODP is a VCOA (**V**isual **C**limb **O**ver **A**irport), you may choose to fly it, but must advise ATC prior to departure that you will be flying the VCOA. Failure to tell ATC could really mess up the traffic flow.

ODPs are created when obstacles require that a climb of more than 200 feet per nm must be maintained for acceptable terrain separation.

 **JEPPESEN**® prints ODPs at the bottom of the runway **diagram** page.



AeroNav puts ODPs in the Terminal Procedures Publication in the “*Takeoff Minimums and Obstacle Departure Procedures*” section — The Triangle T pages

▽ TAKE-OFF MINIMUMS AND (OBSTACLE) DEPARTURE PROCEDURES ▽
 (In the front of the book, following the “INDEX OF TERMINAL CHARTS AND MINIMUMS”).

In conjunction with a prescribed lateral path, the ODP often will require that the aircraft be able to maintain a specified climb gradient steeper than the standard 200 feet nm.

Takeoff Minimums for an ODP – Example

VERNAL, UT

VERNAL RGNL

TAKE-OFF MINIMUMS: **Rwy 16**, 1500-2 or std with a min. climb of 250' per NM to 7000'. **Rwy 25**, 1500-2 or std. with a min. climb of 390' per NM to 7000. **Rwy 34**, 1600-2 or std. with a min. climb of 330' per MM to 7000'

DEPARTURE PROCEDURE: Rws 7, 34, turn right. Rws 16, 25, turn left. All aircraft climb direct VEL. Aircraft departing V391 S-bound climb on course. All others climb in holding patter (SE, right turns, 332° inbound). Aircraft SW-bound V208 depart VEL at or above 8400', all others depart VEL at or above 9500'. Continue climb on course to MEA or assigned altitude.

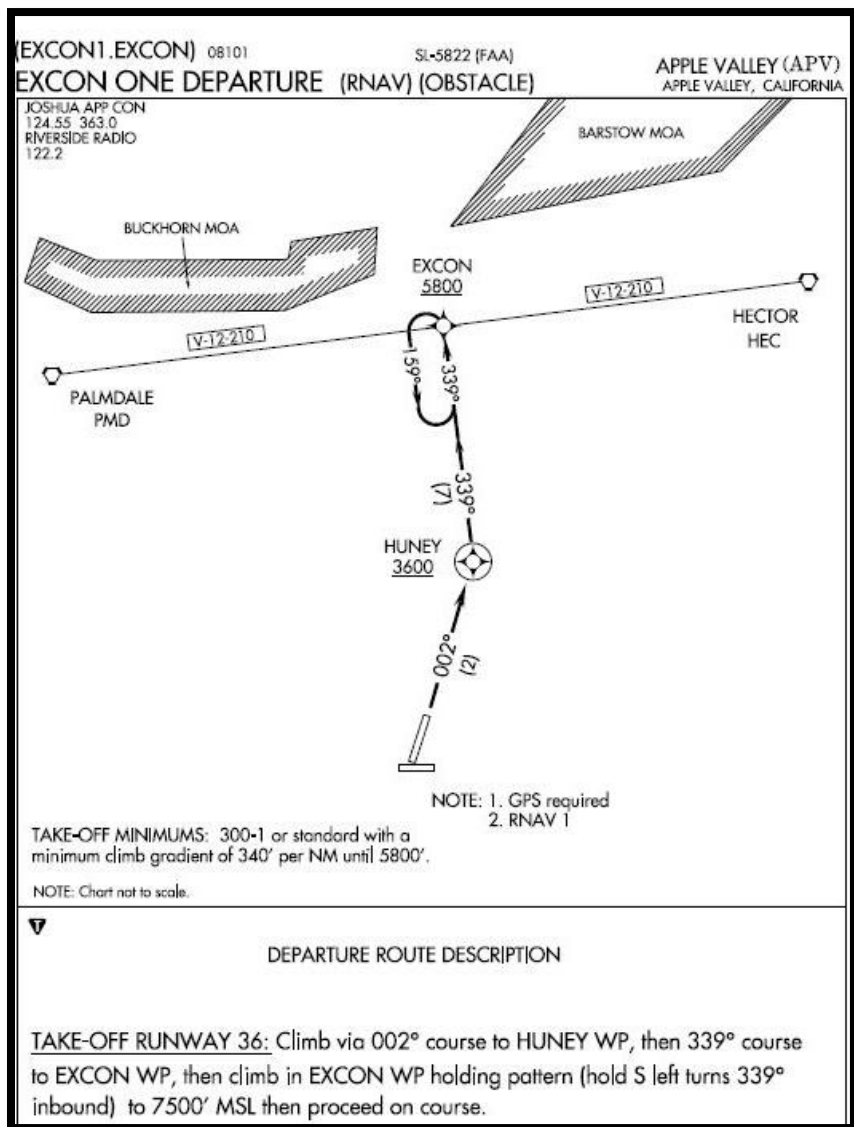

If the ODP is graphical and included in your clearance, you must fly it.

Some ODPs are graphically displayed as if it were a SID, like the EXCON ONE DEPARTURE (RNAV) (OBSTACLE) in Apple Valley, CA (KAPV).

(Wouldn't you like to know the story behind that name?)

SAN DIEGO, CA

BROWN FIELD MUNI (SDM)

TAKEOFF MINIMUMS AND (OBSTACLE)

DEPARTURE PROCEDURES

AMDT 4 10154(FAA)

TAKEOFF MINIMUMS: **Rwy 8L**, std. w/ min. climb of 570' per NM to 3100. **Rwys 8R,26L**, NA - ATC.

DEPARTURE PROCEDURE: **Rwy 8L**, climbing left turn, thence...**Rwy 26R**, climbing right turn, thence...
...via heading 280° to intercept MZB R-160 to MZB VORTAC.

NOTE: **Rwy 26R**, tree 1284' from DER, 778' left of centerline, 52' AGL/561' MSL.

A Learjet accident in San Diego is a chilling example of how a moment's inattention can lead to disaster. In 2004, a highly experienced crew, flying a well-equipped Learjet from San Diego's Brown Field area, took off after the San Diego Brown Field tower had closed and ignored the published departure procedure. They climbed straight out after departing on runway 8, instead of the climbing left turn that the ODP

suggested. While the weather was VFR, it was a dark night and the high terrain just east of the airport was not visible. The Learjet flew into the side of a mountain.

Visual Climb Over

Airport (VCOA)

Two Scenarios to Consider

a) Weather: Today, the weather is VMC at your departure point, but instrument conditions are in the vicinity and are forecast to prevail along the mountainous route. As you review the IFR departure procedures, you note an unusually high climb gradient required after takeoff, and you don't think you can comply with that climb gradient.

b) Sluggish Climb: After converting the prescribed gradient to a rate of climb, you find that your heavily loaded aircraft may not meet the published aircraft climb performance, or it may leave you little margin.

The VCOA May be a Good, Safe Option

When calling for your IFR clearance, you could request a VCOA departure; visually conducting climbing turns over the airport to the published 'climb-to' altitude before you proceed with the instrument portion of the departure. Textual VCOA procedures are published in the "Take-Off Minimums and (Obstacle) Departure Procedures" section of the *Terminal Procedures Publications* and/or appear as an option on a Graphic ODP."

Travel Tip

If an ODP has not been published for the airport, the following will be indicated:

"TAKE-OFF MINIMUMS: IFR departure not authorized."

This prevents Part 135 operators from performing a takeoff in IMC conditions.

ASHEVILLE, NC

ASHEVILLE RGNL (AVL)

TAKEOFF MINIMUMS AND (OBSTACLE)
DEPARTURE PROCEDURES

ORIG 15344 (FAA)

TAKEOFF MINIMUMS: **Rwy 17**, std. w/ min. climb of 250' per NM to 4600 or 3600-3 for climb in visual conditions.

Rwy 35, std. w/ min. climb of 410' per NM to 5700 or 3600-3 for climb in visual conditions.

DEPARTURE PROCEDURE: **Rwy 17**, climb heading 167° to 4600 before proceeding on course. **Rwy 35**, climb heading 347° to 5700 before proceeding on course.

VCOA: **Rwy 17**, obtain ATC approval for climb in visual conditions when requesting IFR clearance. Climb in visual conditions to cross Asheville Rgnl airport at or above 5600 before proceeding on course. Note: VCOA NA at night. **Rwy 35**, obtain ATC approval for climb in visual conditions when requesting IFR clearance. For climb in visual conditions to cross Asheville Rgnl airport at or above 5600 before proceeding on course. Note: VCOA NA at night.

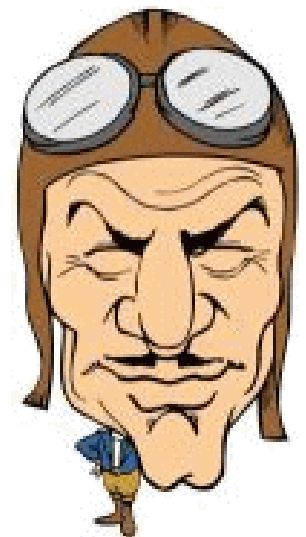

Standard Instrument Departures (SID) or Departure Procedures (DP)

- JEPPESEN SIDs – found at the beginning of each applicable airport’s section.
- AeroNav’s SID Index – “INDEXES OF TERMINAL CHARTS AND MINIMUMS” pages.
- SIDs or DPs are designed to keep aircraft away from the terrain.
- To legally fly a SID, you will need an **ATC clearance** and at a minimum, the **SID or DP’s textual description**.
- To file a SID or DP, start the flight plan with the SID’s code. For instance, Las Vegas’ COWBY FOUR DEPARTURE code is: (COWBY4.COWBY). It ends, or transitions at COWBY.

(COWBY4.COWBY) 11013
 COWBY FOUR DEPARTURE (RNAV) SL-662 (FAA) LAS VEGAS

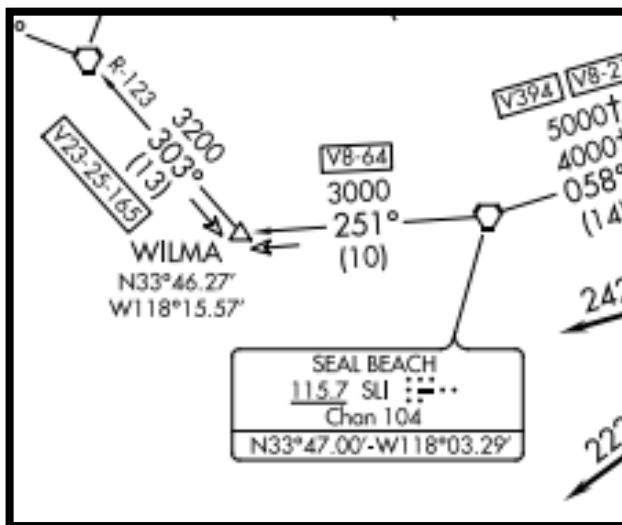

Some SIDs have multiple transitions. For instance, the Anaheim Eight Departure at John Wayne Airport – Orange County (SNA)

On page one of the SID, there’s the SLI (Seal Beach) transition.

But, on page 2, three more transitions are listed. . .

HECTOR TRANSITION (ANAHM8.HEC): From over SLI VORTAC on SLI R-058 and PDZ R-238 to PDZ VORTAC, then on PDZ R-012 to APLES, then on HEC R-232 to HEC VORTAC.

LAKE HUGHES TRANSITION (ANAHM8.LHS): From over SLI VORTAC on SLI R-058 and PDZ R-238 to POXKU, then on POM R-164 to BAYJY, then on VNY R-095 to DARTS, then on LHS R-139 to LHS VORTAC.

VENTURA TRANSITION (ANAHM8.VTU): From over SLI VORTAC on SLI R-251 to WILMA, then on LAX R-123 to LAX VORTAC, then on LAX R-276 to SADDE, then on VTU R-093 to VTU VOR/DME.

Area Navigation (RNAV) SIDs



This SID requires a Flight Management System (FMS) or an IFR certified GPS.

Opting out of the SID

Enter **“No SID”** in the REMARKS section.

Climb Gradients

A specified minimum climb gradient could be required to fly a SID or ODP, especially if mountains are involved.

Below is the climb gradient required for the *Tucson 7 Departure*:

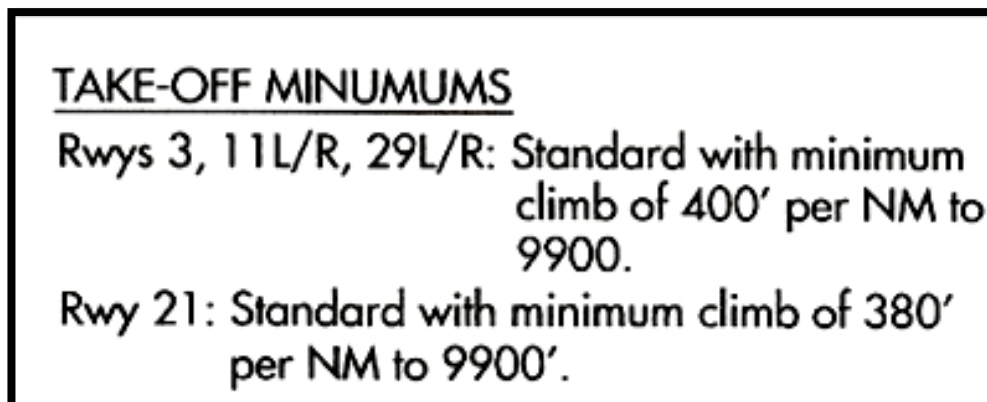

AeroNav and *Jeppesen* both publish tables to convert a **feet per nm** gradient to a **rate of climb in feet per minute**.



AeroNav's CLIMB/DESCENT TABLE is published on the inside of the back page of the Terminal Procedures Publication (approach plates booklet).

Example: If your climb ground speed is 90 knots, to maintain 400' per NM (a 4.0 climb gradient), you'll need to maintain a vertical speed of at least 640 feet per minute. At 120 knots Ground Speed, you'll need 850 FPM.

INSTRUMENT TAKEOFF OR APPROACH PROCEDURE CHARTS RATE OF CLIMB/DESCENT TABLE

(ft. per min)

A rate of climb/descent table is provided for use in planning and executing climbs or descents under known or approximate ground speed conditions. It will be especially useful for approaches when the localizer only is used for course guidance. A best speed, power, altitude combination can be programmed which will result in a stable glide rate and altitude favorable for executing a landing if minimums exist upon breakout. Care should always be exercised so that minimum descent altitude and missed approach point are not exceeded.

CLIMB/ DESCENT ANGLE (degrees and tenths)	ft/NM	GROUND SPEED (knots)											
		60	90	120	150	180	210	240	270	300	330	360	
2.0	210	210	320	425	530	635	743	850	955	1060	1165	1275	
2.5	265	265	400	530	665	795	930	1060	1195	1325	1460	1590	
VERTICAL PATH ANGLE	2.7	287	287	430	574	717	860	1003	1147	1290	1433	1576	1720
	2.8	297	297	446	595	743	892	1041	1189	1338	1486	1635	1783
	2.9	308	308	462	616	770	924	1078	1232	1386	1539	1693	1847
	3.0	318	318	478	637	797	956	1115	1274	1433	1593	1752	1911
	3.1	329	329	494	659	823	988	1152	1317	1481	1646	1810	1975
	3.2	340	340	510	680	850	1020	1189	1359	1529	1699	1869	2039
	3.3	350	350	526	701	876	1052	1227	1402	1577	1752	1927	2103
	3.4	361	361	542	722	903	1083	1264	1444	1625	1805	1986	2166
3.5	370	370	555	745	930	1115	1300	1485	1670	1860	2045	2230	
4.0	425	425	640	850	1065	1275	1490	1700	1915	2125	2340	2550	

If you can't locate the RATE OF CLIMB tables, here's a tip: *If you know your Ground Speed (GS), you can do the math. (Climb Gradient is Feet/Mile)*

$$\frac{\text{Climb Gradient} \times \text{GS}}{60} = \text{Ft/min}$$

For example, if taking off on Tucson's RWY 11L or 11R, (shown below), the required climb gradient is 400 feet per nautical mile (nm).

TAKE-OFF MINIMUMS

Rwys 3, 11L/R, 29L/R: Standard with minimum climb of 400' per NM to 9900.

$$\frac{400}{60} \times 100 = 666$$

Using a **100-knot climb ground speed**, this climb gradient requires 666 feet per minute rate of climb to 9,900 feet MSL.



Feet / nm

No ODP or Climb Gradient Published?

If a climb gradient is not published, the required minimum climb gradient is 200 feet per nautical mile.

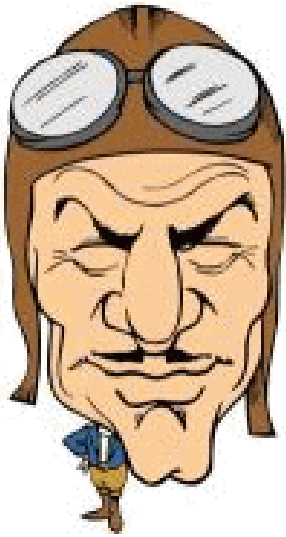

Travel Tip

“Standard” takeoff minimums apply to Part 135 operators, but Part 91 operators would be wise to also follow the required climb gradient.

IFR Cruising Altitudes

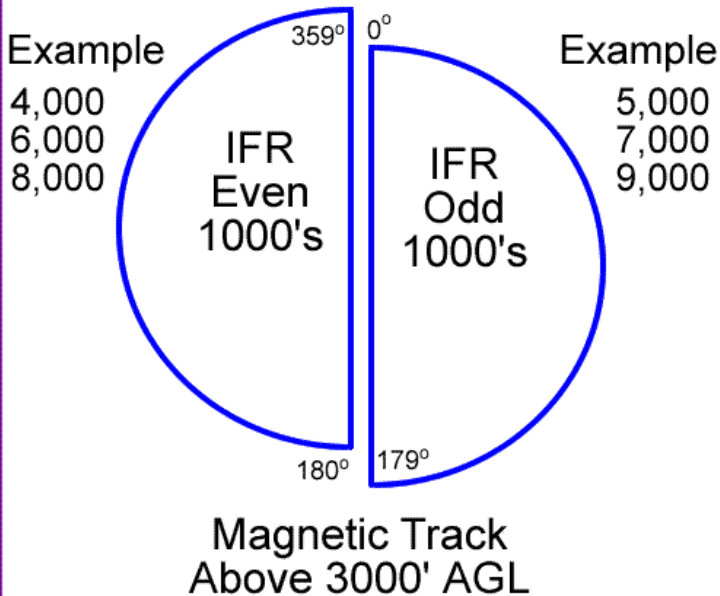

IFR Altitudes

- **In Controlled Airspace**, ATC can clear you to fly at an EVEN or ODD altitude, regardless of your magnetic track heading.
- **In Uncontrolled Airspace**, you must fly the correct hemispheric altitude based on your track. (FAR 91.179)

VFR on Top (AIM 4-4-8)

This starts with an IFR flight plan and an IFR clearance. Once on top of the clouds and able to maintain VFR cloud clearance, you may declare "VFR on top."

Here are the procedures you must now follow:

- Fly the appropriate hemispheric VFR altitudes.
- VFR cloud clearances and visibility now apply.
- Follow VFR **and** IFR rules.
- Report changes in altitude to ATC.
- Separation from other traffic may not happen. The pilot is responsible for seeing and avoiding all aircraft.
- Clearance to operate "VFR-on-top in VFR conditions" does not imply cancellation of the IFR flight plan, so don't forget to close your flight plan or cancel IFR.

Cruise Clearance (AIM 4-4-3)

- ATC will assign a block of airspace – any altitude from the minimum IFR altitude up to and including the altitude specified in the clearance.
 - For example: "Bonanza 34 Delta Bravo, cleared to the Natchitoches Airport, cruise three thousand".
- You can level off or climb or descend in this block of airspace. However, once the pilot reports that he or she is descending from an altitude in the block of airspace, he or she may not return/climb without additional ATC clearance.

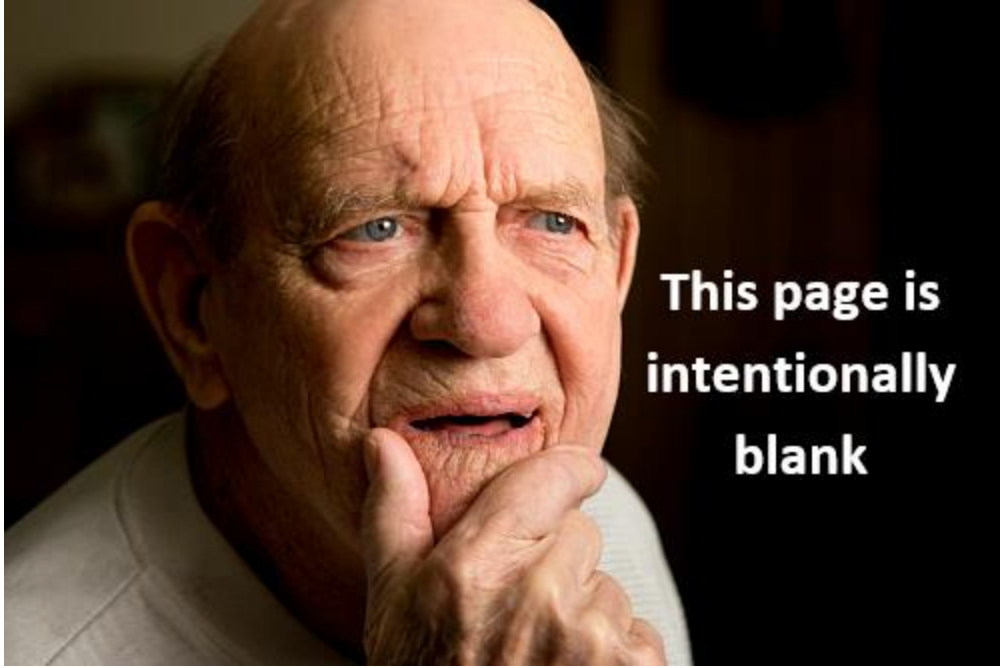

Holding

Common Sense Holding

Step 1 – Diagram ATC’s instructions. For example, if you are instructed to: “Hold on the Fairfield (FFU) 270 degree radial, 40 DME fix.”, draw it like this:



Step 2 – Visualize your position on the chart or approach plate and mark it. Then, chop the holding pattern in half, (as shown below).

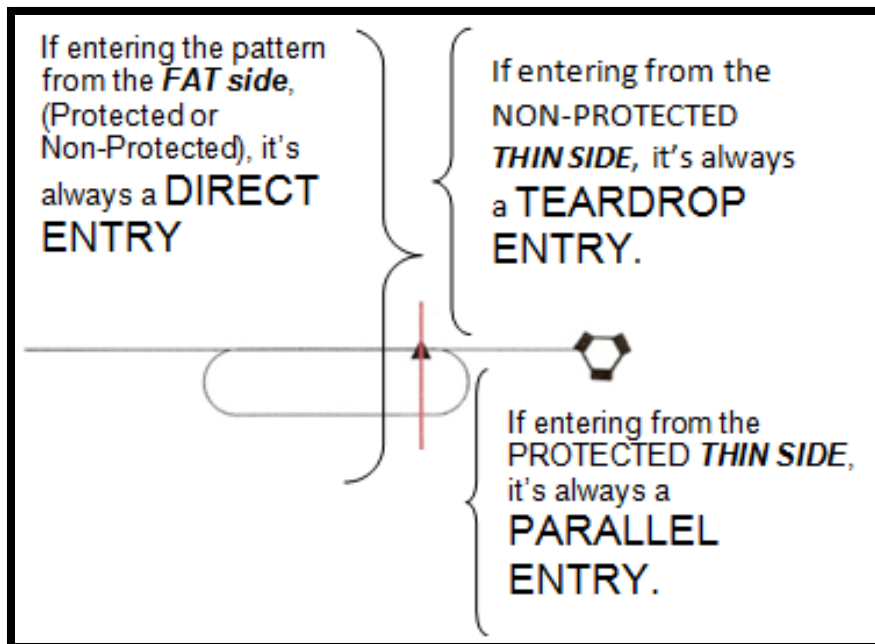

Basic Holding Rules

- STANDARD PATTERNS – RIGHT turns
- NON-STANDARD PATTERNS – LEFT turns

Entering a hold is a required report — even when you are in radar contact.

Holding times

- **At or below** 14,000' MSL – Hold 1 Min.
- **Above** 14,000' MSL — Hold 1 1/2 Min.
 - The outbound timing starts when wings level or abeam the fix, whichever occurs **last**.

Holding Airspeeds

At least three minutes before the estimated arrival at the holding fix, slow to holding airspeed:

Up to 6,000' MSL, hold at:	200 KIAS maximum
6,001' to 14,000' MSL, hold at:	230 KIAS maximum
Above 14,000' MSL, hold at:	265 KIAS maximum
Unless depicted otherwise	



Correcting the Inbound Time (1 Minute Pattern example)

- If the trip *inbound* to the fix is less than 1 minute, adjust the outbound leg by 2/3 the difference. For instance, if the inbound trip takes 40 seconds. 2/3 of the 20 second difference is 14 seconds. Fly the next outbound leg for 74 seconds.
- If the *inbound* trip exceeds 1 minute, adjust the outbound time by 1/3 the difference. For instance, if the inbound leg took 80 seconds. 1/3 of the 20 second difference is 7 seconds. Fly the next outbound leg for 53 seconds.

LESS than the 1 or 1 ½ minutes — adjust by **MORE** (2/3).
MORE than the 1 or 1 ½ minutes — adjust by **LESS** (1/3).

Correcting Course

The HDG correction needed to maintain the inbound course should be doubled on the outbound leg. For instance, if you have a 5° crab on the inbound leg, apply a 10° correction on the outbound leg.

STARS

Filing a STAR

AeroNav's presentation of Houston's GLAND THREE ARRIVAL (KIAH), (GLAND.GLAND3), requires two pages, with the ARRIVAL DESCRIPTION on page 2. If you plan to join the STAR at Corpus Christi (CRP), file: **CRP.GLAND3**.

- Some transitions are “**ATC assigned**”, like the KAWSE-1, KAWSE-3 & MILNY transitions, shown below. You should NOT file those transitions.
- **As a minimum, you must** have the STAR's textual description in the cockpit.

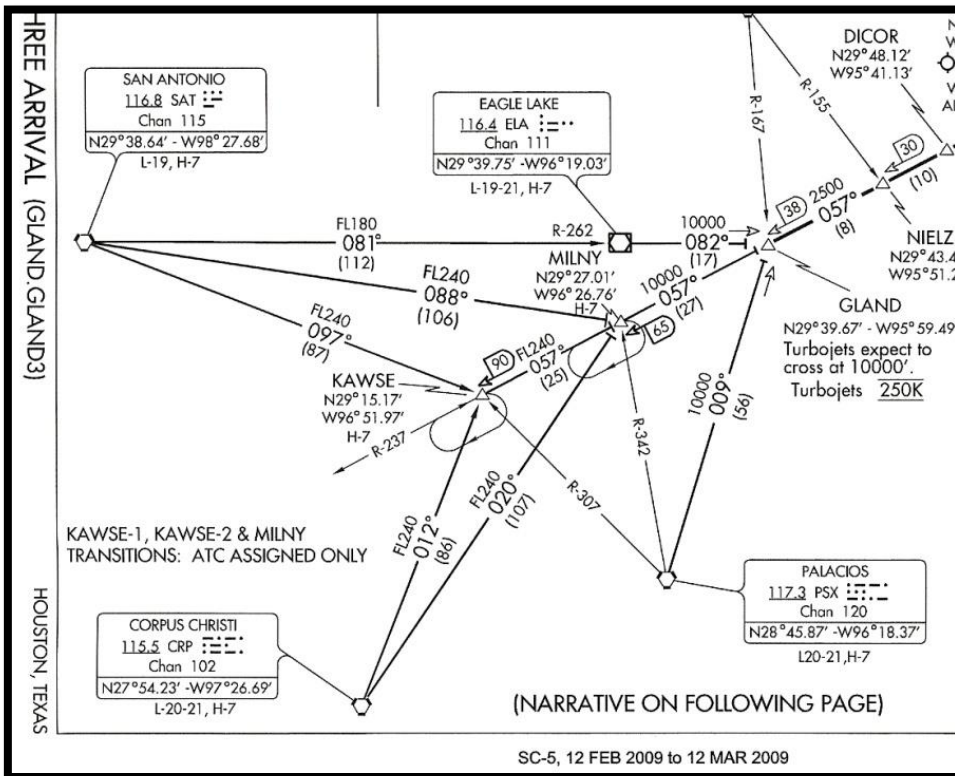

Opting Out of a STAR

Enter “**NO STAR**” in the remarks section of the flight plan.



RNAV STARS require FMS or GPS

RNAV STARS have published mandatory speeds and / or crossing altitudes. Published expected altitudes and speeds are for **planning purposes only**.

Possible RNAV STAR Clearances

- **“Cleared HADLY ONE arrival, descend and maintain 12,000.”**
 - **Translation:** You are cleared to navigate laterally, and descent to 12,000 feet.
- **“Cleared HADLY ONE arrival.”**
 - **Translation:** You may navigate laterally ONLY.
- **“Descend via the HADLY ONE arrival.”**
 - **Translation:** Those are the magic words! You may now navigate laterally and vertically, descending via the STAR’s altitude restrictions.

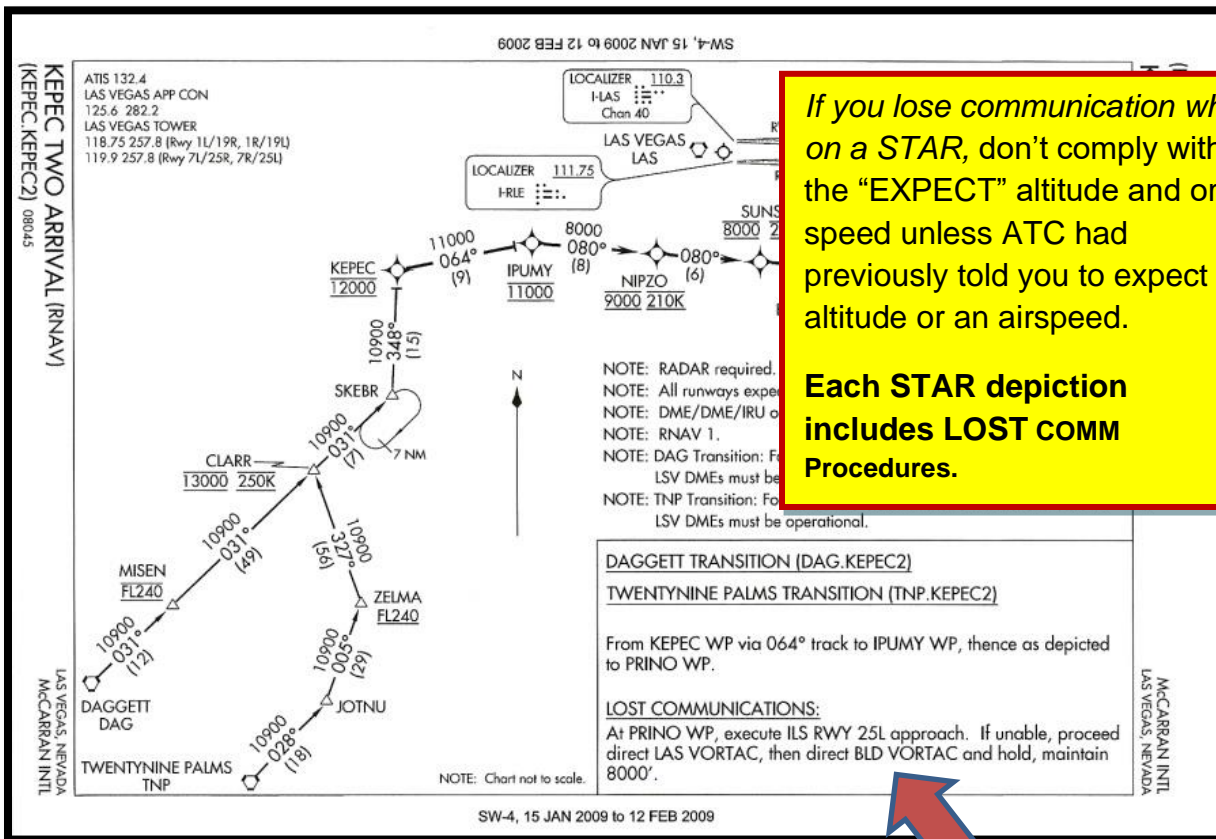

If you lose communication while on a STAR, don't comply with the "EXPECT" altitude and or speed unless ATC had previously told you to expect an altitude or an airspeed.

Each STAR depiction includes LOST COMM Procedures.

Instrument Approaches

Briefing the Approach

Do it out loud! There is something about verbalizing the approach that etches the information in the memory.

After obtaining the current weather, start your briefing with the information in the top “briefing box”:

TUCSON, ARIZONA		AL-430 (FAA)		ILS or LOC RWY 11L TUCSON INTL (TUS)	
LOC/DME I-TUS 111.7 Chan 54	APP CRS 123°	Rwy Idg 10996 TDZE 2599 Apt Elev 2643			
▼ For inoperative MALSR, increase S-ILS 11L Cat E visibility to RVR 5000, S-LOC 11L Cat D and Cat E visibility to RVR 5000. ADF or DME required.		MALSR 	MISSED APPROACH: Climb to 4000 then climbing right turn to 6000 via heading 300° and TUS R-270 to RYN NDB/TUS 12.8 DME and hold.		
ATIS 123,8 279,65	TUCSON APP CON 119,4 318,1	TUCSON TOWER 118,3 257,8	GND CON 124,4 348,6	CLNC DEL 126,65 326,2	
(IAF)					

Things to consider while briefing:

- Ensure the proper and current approach plate is selected. (Approaches are effective 0901Z on the day specified).
- Ensure the correct NAVAIDs are tuned and identified.
- Ensure the marker audio is ON.
- If it's an RNAV/GPS approach, ensure that the correct approach has been selected in your GPS.
- Commit to memory the first heading and altitude of the Missed Approach procedure.
- What type of runway and approach lighting can you expect?
- Is the lighting Pilot Controlled?

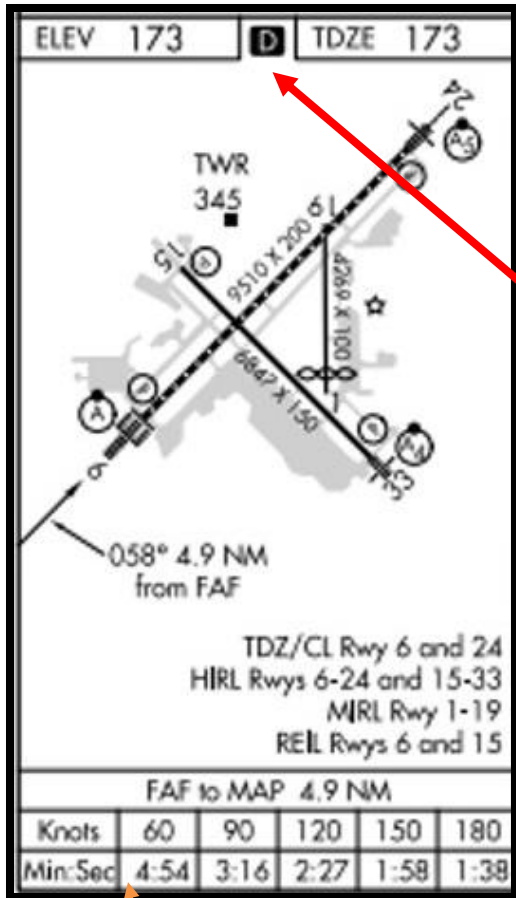

Check the runway diagram for:

- Runway lighting types, such as HIRL, MIRL, etc.
- Approach lighting
- REIL
- PAPI, VASI & PLASI

The negative “D” indicates that runway declared distance information is available in the **Chart Supplement** (formerly the Airport Facility Directory or A/FD).

The distance information is broken down into:

- TORA: Take off run available,
- TODA: Take off distance available,
- ASDA: Accelerate stop distance, available

&

- LDA: Landing distance available

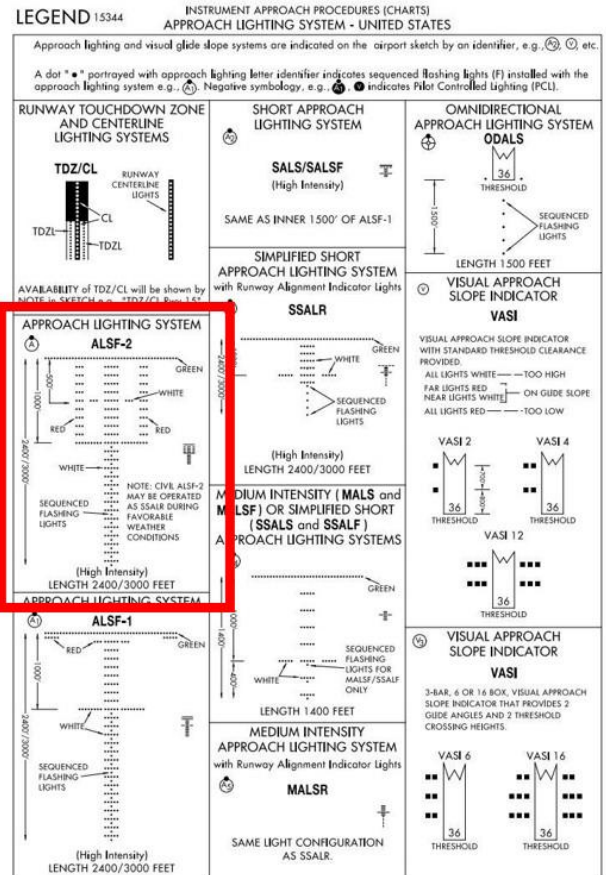

The type of Approach Lighting is shown in the lower corner runway diagram (shown above)

The type of Approach Lighting is annotated at the top briefing box (shown below)

WINDSOR LOCKS, CONNECTICUT		AL-460 (FAA)		20086
LOC/DME I-BDL 111.1 Chan 48	APP CRS 058°	Rwy Idg 9509 TDZE 173 Apt Elev 173	ILS or LOC RWY 6 BRADLEY INTL (BDL)	
RADAR required for procedure entry.		ALSF-2	MISSED APPROACH: Climb to 4000 then left turn direct BAF VORTAC and hold.	
YANKEE APP CON				

You can learn more about the approach lighting by referring to the **LEGEND** in the Terminal Procedures publication (shown at right)

INOP COMPONENTS
07018

INOPERATIVE COMPONENTS OR VISUAL AIDS TABLE

Landing minimums published on instrument approach procedure charts are based upon full operation of all components and visual aids associated with the particular instrument approach chart being used. Higher minimums are required with inoperative components or visual aids as indicated below. If more than one component is inoperative, each minimum is raised to the highest minimum required by any single component that is inoperative. ILS glide slope inoperative minimums are published on the instrument approach charts as localizer minimums. This table may be amended by notes on the approach chart. Such notes apply only to the particular approach category(ies) as stated. See legend page for description of components indicated below.

(1) ILS, MLS, PAR and RNAV (LPV line of minima)

Inoperative Component or Aid	Approach Category	Increase Visibility
ALSF 1 & 2, MALSR, & SSALR	ABCD	1/4 mile

(2) ILS with visibility minimum of 1,800 RVR

ALSF 1 & 2, MALSR, & SSALR	ABCD	To 4000 RVR
TDZL RCLS	ABCD	To 2400 RVR
RVR	ABCD	To 1/2 mile

(3) VOR, VOR/DME, TACAN, LOC, LOC/DME, LDA, LDA/DME, SDF, SDF/DME, GPS, ASR and RNAV (LNAV/VNAV and LNAV line of minima)

Inoperative Visual Aid	Approach Category	Increase Visibility
ALSF 1 & 2, MALSR, & SSALR	ABCD	1/2 mile
SSALS, MALS, & ODALS	ABC	1/4 mile

(4) NDB

ALSF 1 & 2, MALSR, & SSALR	C	1/2 mile
MALS, SSALS, ODALS	ABD	1/4 mile
	ABC	1/4 mile

CORRECTIONS, COMMENTS AND/OR PROCUREMENT

FOR CHANGES, ADDITIONS, OR RECOMMENDATIONS ON PROCEDURAL ASPECTS CONTACT:

FAA, Aeronautical Information Services, ATO-R
800 Independence Avenue, SW
Washington, DC 20591
Telephone 1-866-295-8236

FOR PROCUREMENT CONTACT:

FAA, National Aeronautical Charting Office
Distribution Division, ATO-W
10201 Good Luck Road
Glenn Dale, MD 20769-9700
Online at www.naco.faa.gov
Email 9-AMC-Chartsoff@faa.gov
Telephone 1-800-638-8972
Fax 301-436-6829
or any authorized chart agent

FOR CHARTING ERRORS CONTACT:

FAA, National Aeronautical Charting Office, ATO-W
SSMC-4, Sta. #2335
1305 East West Highway
Silver Spring, MD 20910-3281
Telephone 1-800-626-3677
Email 9-AMC-Aerochart@faa.gov

Frequently asked questions (FAQ) are answered on our website at www.naco.faa.gov. See the FAQs prior to contact via toll free number or email.
Request for the creation or revisions to Airport Diagrams should be in accordance with FAA Order 7910.4.

INOP COMPONENTS
07018

When approach lighting system components are inoperative, the required visibility increases. You can find the increase in the Terminal Procedures publication, INOP COMPONENTS page.

Pilot Controlled Lighting (PCL)

While the CTAF is commonly used to activate pilot-controlled lighting, the proper frequency, if different from the CTAF, can be found in the Chart Supplement (formerly the Airport Facility Directory or A/FD) and on standard instrument approach procedure charts.



Sample entry from the Chart Supplement: “**When twr clsd ACTIVATE HIRL Rwy 10-26 – CTAF**”.

Clicking seven times in five seconds should give you the highest intensity.



When the reverse L symbol is found next to the frequency on the Approach Chart, this indicates PCL



Pilot Controlled Lighting may use a frequency other than the CTAF. Check the Chart Supplement (formerly the Airport Facility Directory or A/FD) for the **PCL Frequency**

Pilot Controlled Lighting (PCL)



PCL is activated, a 15-minute countdown starts, after which the lights turn off unless someone makes the appropriate number of clicks on the appropriate frequency.

Always initially key the mike 7 times to assure that all controlled lights are turned on to the maximum available intensity. If desired, an intensity adjustment can then be made, (where the capability is provided).

Even when the lights are on, always key the mike as directed when overflying an airport of intended landing, or just prior to entering the final segment of an approach. This will make sure that the aircraft is close enough to activate the system and **a full 15 minutes of lighting duration will be available.**

Next, look at the profile view

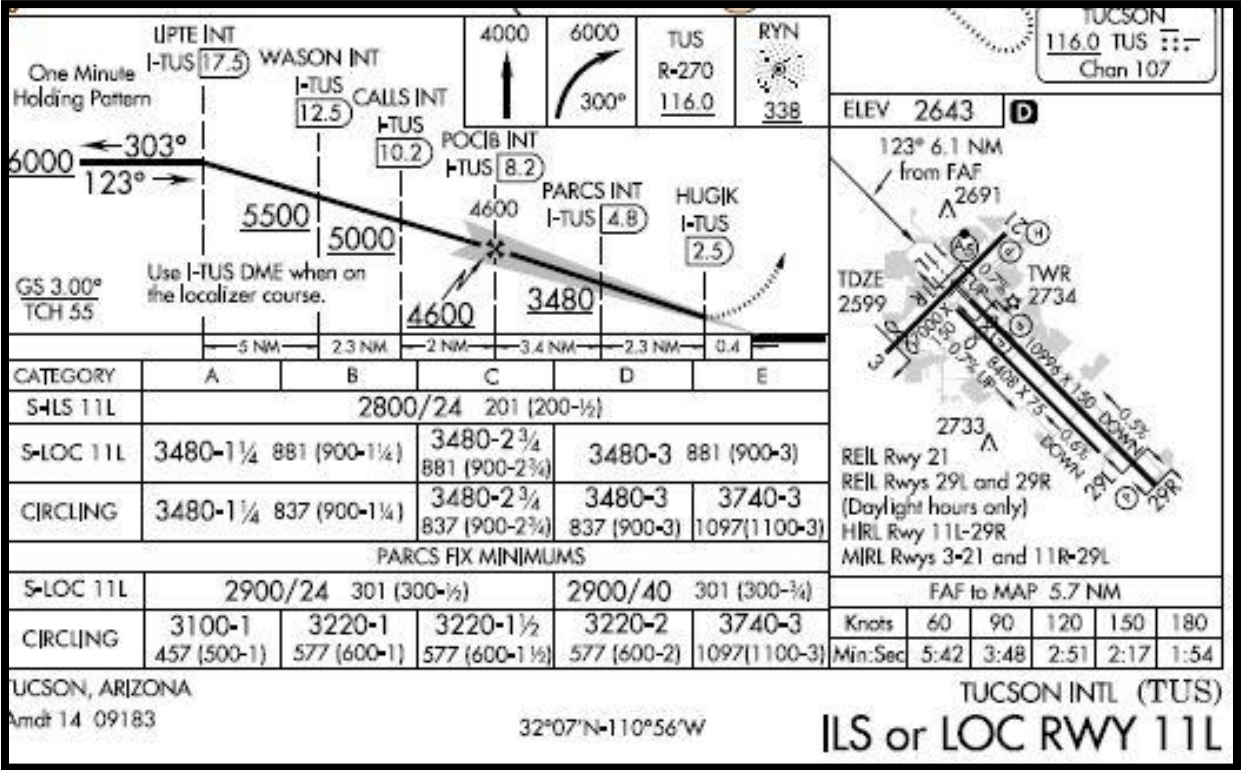

Things to consider:

- **When Briefing a Precision Approach:**
 - The step-down altitude(s), the glide slope interception altitude, the altitude at which you will cross the marker, and the approximate rate of descent in Feet per Minute.
 - The DH and the weather required. Note: If an 1800 RVR is authorized, the pilot must use either a Flight Director, Autopilot, or Heads Up Display (HUD), all the way to the decision height.
 - As a backup to the ILS, what is the Localizer MDA?

Sometimes the conditions warranting applying the lower 1800 RVR authorized is spelled out on the approach plate. For instance, the ILS RWY 13 at Corpus Christi (KCRP):

▼	For inop MALSR, increase S-ILS 13 Cat E visibility to RVR 4000 and S-LOC 13 Cats C/D/E visibility to RVR 5500.	MALSR	
▲	#RVR 1800 authorized with use of FD or AP or HUD to DA.	(A5)	[Symbol]

CATEGORY	A	B	C	D	E
S-ILS 13#			246/24	200 (200-½)	

- **When Briefing a Non-precision Approach:**
 - Step down altitude(s).
 - If a VDP is not indicated, calculate a VDP for a 3° glideslope, and the approximate rate of descent in Feet per Minute.
 - The MDA and the weather required.
 - The runway's length, lighting, VASI/PAPI, etc.
 - FAF to the MAP – the distance and time.

Look at the “bird’s eye” view

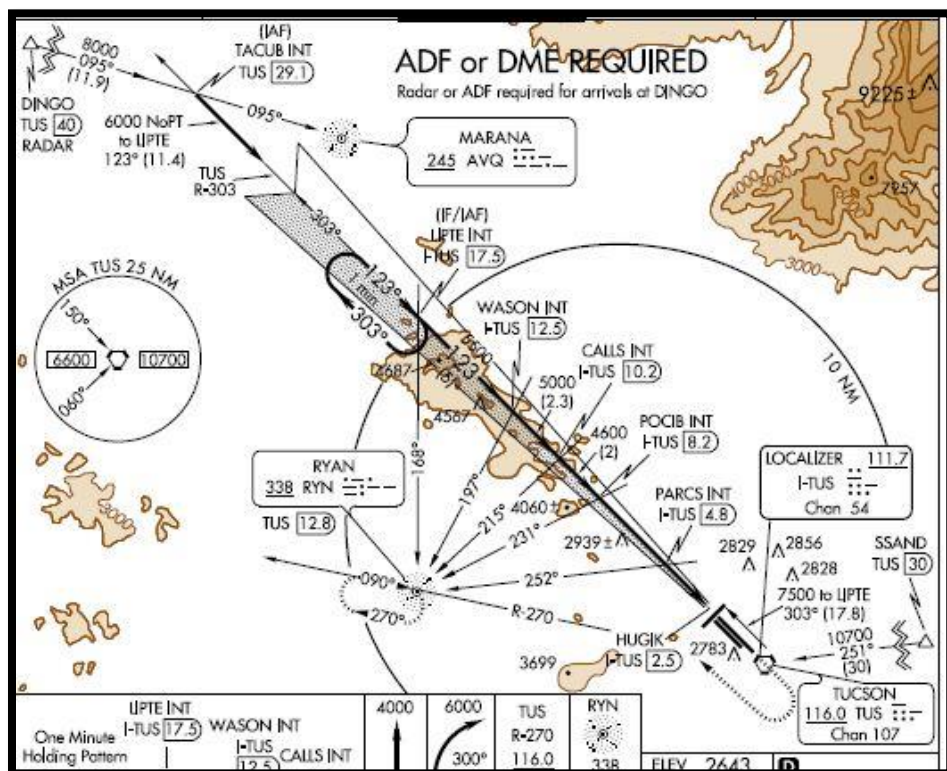

Consider:

- The MSA, highest obstruction(s) and terrain.
- Notes and warnings.
- Important NAVAIDs and courses.

Finally, look at the airport diagram and consider:

- The planned runway exit(s) and potential hot spots
- Your taxi plan – from the runway to the ramp.

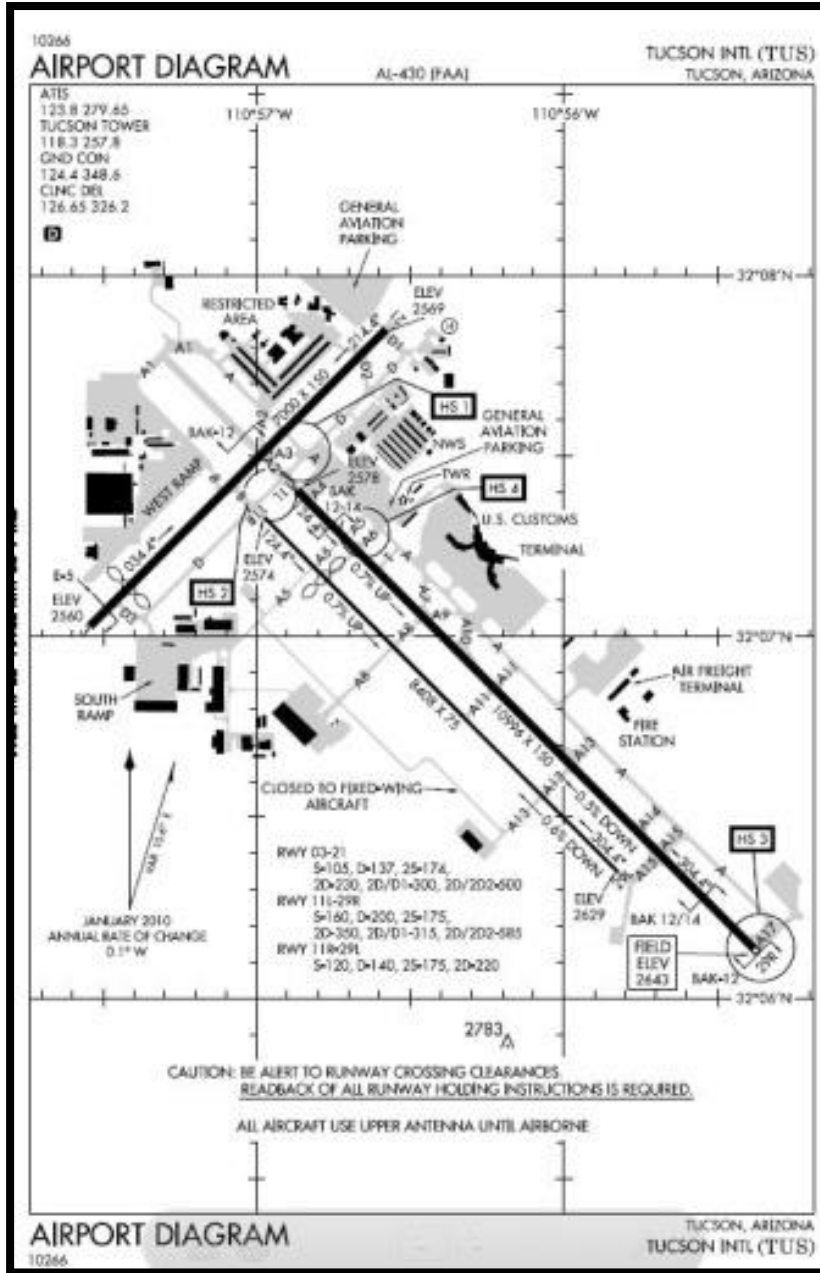



GPS World

Don't forget to "Brief" the GPS

If you have a GPS, don't forget to "brief" it too. Scroll through the approach and the missed approach waypoints and make sure everything is there.

Approach Clearance

If a feeder route to an IAF begins at a fix located along the route of flight that precedes the holding fix, and clearance for an approach is issued, you should commence the approach via the published feeder route.

A Blank Check

Sometimes ATC may not specify a particular approach procedure in the clearance, but may say, "Cleared Approach." That means you can execute any of the authorized approaches for that airport.

This clearance **does not** authorize a Contact or Visual approach.

Using the Autopilot, Part 135 Operations (FAR 135.95)



- It may be engaged in the descent through no lower than 500' AGL, except when flying an instrument approach.
 - When flying a non-precision approach, disengage at no lower than 50 feet above the **MDA**.
 - When flying an ILS approach, the autopilot must be disengaged no lower than 50 feet above the **terrain**

Preparing for the Approach



A	ATIS
B	Brief the approach.
C	Checklist.
M	Marker Beacon Audio ON.
A	Altimeter SET (Also, set the bug to the MDA/DH).
I	Indicators (Set frequencies, courses, etc.).
D	DG SET, unless you are fortunate enough to have an HSI.

Approach Basics, applying to all approaches

- Brief the approach and accomplish **ABC MAID**.
- You may descend from ATC's assigned altitude to the published altitude that begins the approach when you are "**10-10 and Cleared.**" Meaning:
 - You are within 10 nm of the runway, 10⁰ of the approach course, and cleared for the approach.
- ATC will not turn you over to the tower controller unless you are established on the final approach course.

Procedure Turns

At the initial approach fix, slow to approach speed. Depending on the wind, fly outbound for 2 to 4 minutes. Remain within 10 nm, or as charted on the approach.

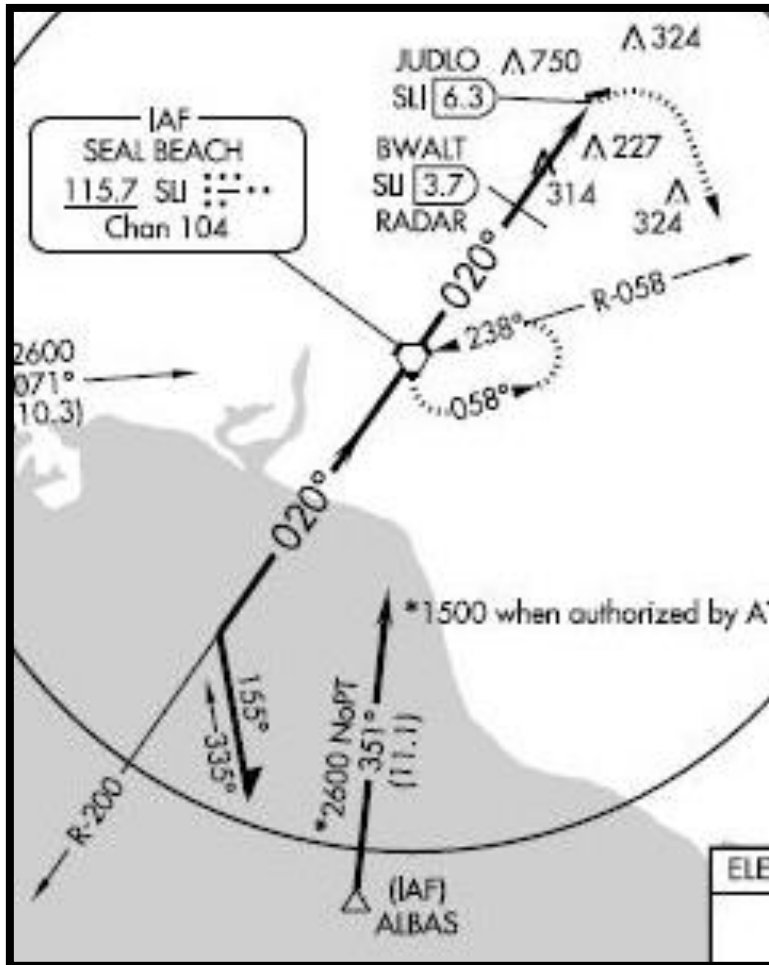

THEN . . .

Turn 45°, as charted and fly for 1 to 2 minutes.

This is a good time to check that the heading indicator matches the magnetic compass.

THEN . . .

Start a 180° turn, as charted, to intercept the inbound course.

Report “Procedure turn inbound”, or as directed by ATC.

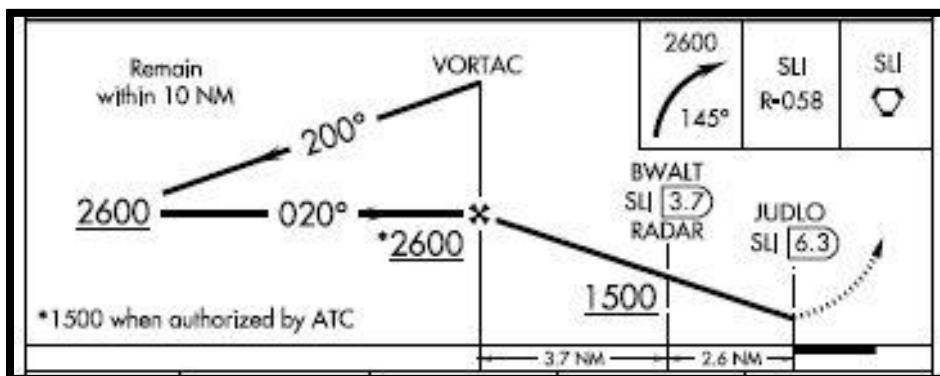
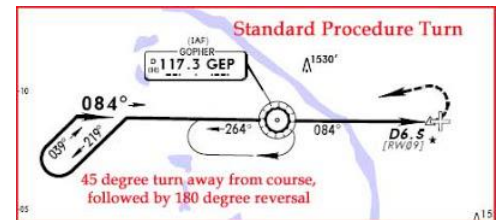

Holding Pattern in Lieu of a Procedure Turn

- Hold as depicted.
- Do not exceed the protected or designated holding airspace.
- Descend in the holding pattern.
- Report "Procedure turn inbound", or as directed by ATC

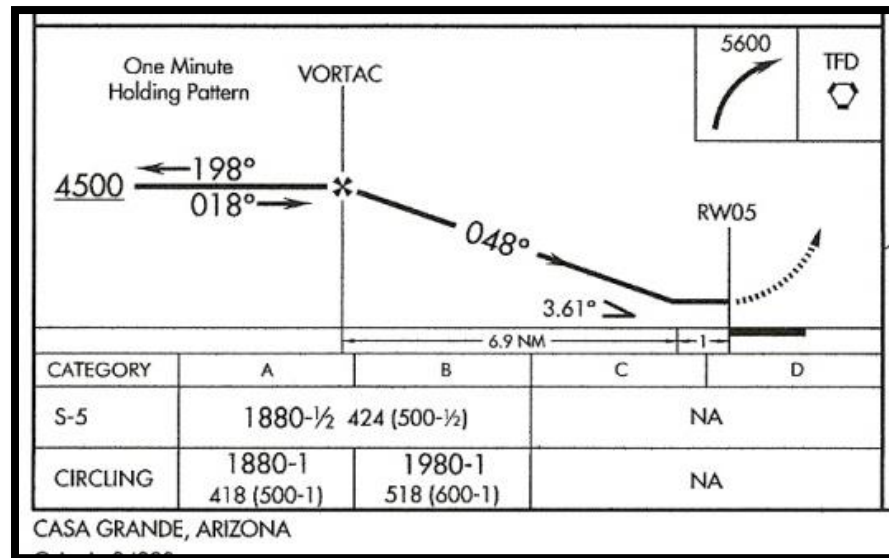
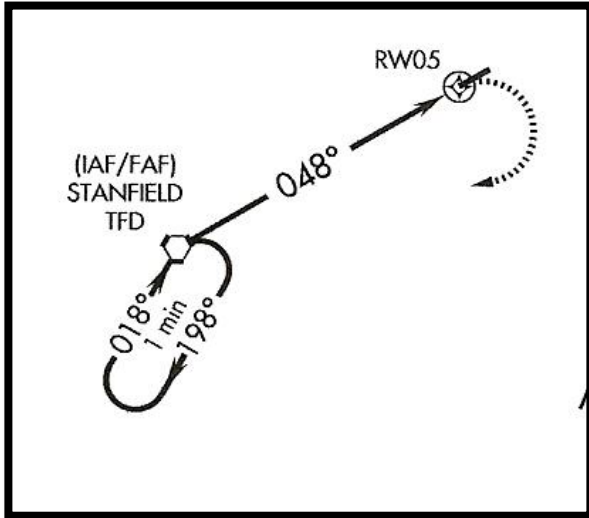

Arcing and Leading the Arc

It takes 2 minutes to make a standard rate, 360° turn. Therefore, to turn 90°, a standard rate turn requires 30 seconds.

- Determine your ground speed and convert it to nautical miles per minute, by dividing the GS by 60.
- Because you will need 30 seconds to make the 90° turn, divide the **miles per minute** by two – giving you the number of nautical miles that you’ll need to “lead the turn”:

If your GS is:	Divide miles per minute by 2:	Lead the turn by:
100 knots / 60 = 1.7 miles/min	1.7 / 2 =	.85 (8/10) nm
120 knots / 60 = 2 miles/min	2 / 2 =	1 nm
150 knots / 60 = 2.5 miles/min	2.5 / 2 =	1.25 nm (1 ¼) nm

Arcing Situation:

Flying westward toward JEBNO, established on PRB’s 077° radial.

If your ground speed is 120 knots, one mile before JEBNO and the arc, turn RIGHT 90°, to 347°.

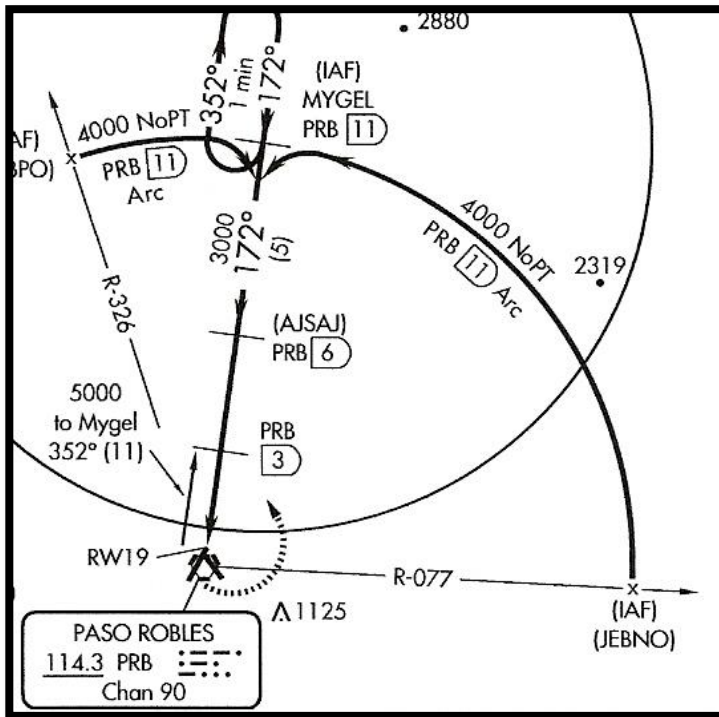

Roll out on heading 347° and select the next 10° bearing TO the station — **247°**. (The CDI/HSI needle should be off to the left).

As the CDI/HSI moves from the left to the center, select the next 10° bearing change, (**237°**). Turn left as necessary to stay on the 11 DME arc.



Arcing Travel Tips

- If you are inside the arc, don't make any turns toward the VOR until you again catch the desired arc.
- If you are outside the arc, make a 20° correction to return to the arc.
- **For clockwise arcing:** the next radial inbound course will be +10°. Turn your OBS **clockwise** as you arc.
- **For counterclockwise arcing:** the next radial inbound course will be minus 10°. Turn your OBS **counterclockwise** as you arc.

Intercepting a Radial from the Arc

Miles from the VOR	Degrees per nautical mile
10 miles	6°
15 miles	4°
30 miles	2°
60 miles	1°

- At 120 knots, a 90° turn takes 1 nm. If you are on the 10 nm arc, a 90° turn takes 1 nm or 6 degrees to lead the radial.
- At 100 knots, on the 10 nm arc, a 90° turn takes .85 nm. $.85 \times 6^\circ = 5.1^\circ$ to lead the radial.
- At 150 knots, on the 10 nm arc, a 90° turn takes 1.25 nm. $1.25 \times 6^\circ = 7.5^\circ$ to lead the radial.

ILS Approach

- Assuming that the LOC approach is your backup approach, start the timer at the FAF.
- You may descend from the ATC assigned altitude to the published altitude that begins the approach when you are "**10-10 and Cleared.**" (Within 10 nm of the runway, 10° of the approach course, and cleared for the approach).

WARNING: To avoid false glide slopes, (9° and 15° descent angles), you must intercept the GS from below.

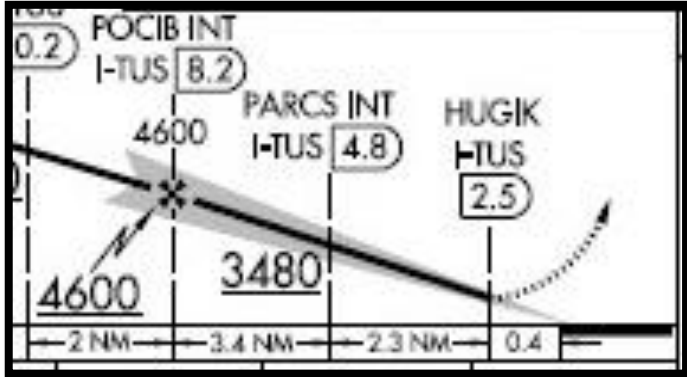

Note your altitude as you pass “the marker” and compare that altitude to the charted altitude shown in the profile view. For example, on the TUS ILS 11L, you should cross **POCIB** intersection at 4,600 feet.

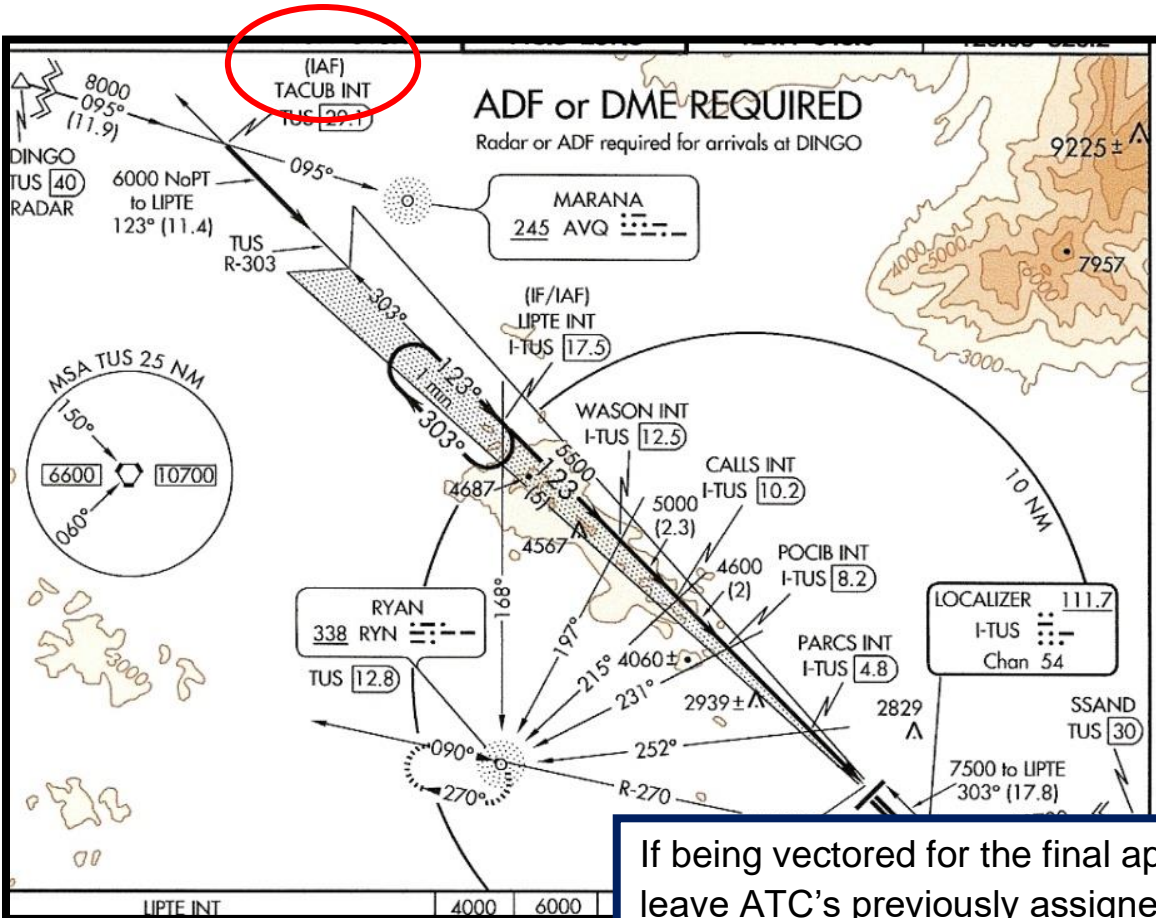

If being vectored for the final approach course, never leave ATC’s previously assigned altitude until you are on a **published segment** of the approach. Reference the KTUS ILS or LOC RWY 11L approach, the *published segment* is denoted by **heavy black lines**, starting at **TACUB** intersection, and the segment altitude - 6,000 feet.

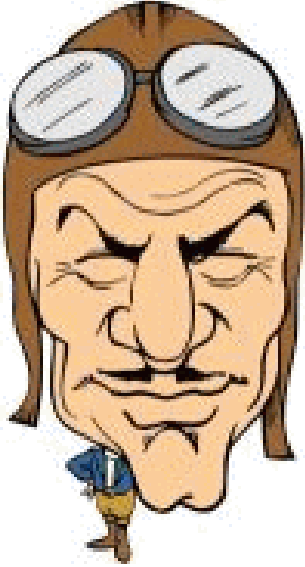

To quickly calculate the target descent rate for an ILS's 30 glide slope:

Ground speed X 5 = Feet per minute rate of descent.

EXAMPLE: 100 knots GS X 5 = 500 FPM target descent rate.

VASI and the ILS Approach (FAR 91.129)

If a runway has an operational VASI, you must remain at or above the glide slope until a lower altitude is necessary for landing.

ILS/LOC & VOR Approaches

- Monitor the ILS/LOC or VOR receiver's Morse code.
- Use both receivers for a VOR approach.

LOC and BC Approach

- The Back-Course approach must be a published approach, (Not a homemade approach)
- Always set the Front Course in the CDI or HSI. If you have an HSI, it might have a reverse sensing capability.
- If you don't have reverse sensing capability, then you must "steer away" from the localizer needle when flying inbound on the LOC BC.
- Start timing at the FAF.

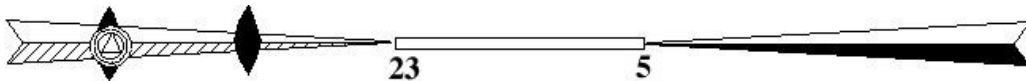

Contact Approach (AIM 5-4-23)

- It is never assigned by ATC – You must request it.
- ATC will provide separation between IFR and Special VFR traffic.
- The airport must have an instrument approach procedure and 1-mile visibility.
- A Contact Approach does not have a Missed Approach Procedure

In addition, you should:

- Stay clear of clouds &
- Passionately believe that you'll continue to the airport successfully.

No Gyro Approach

- When ATC says, "Turn left" or "Turn Right", start the turn immediately.
- When you hear, "Stop turn", stop the turn immediately.
- ATC will instruct you to make half standard rate turns on final.

Sidestep Approaches

As soon as the runway to which you are cleared to land is in sight, begin a sidestep maneuver to the extended centerline of the landing runway.

The Circling Approach

A circling approach is a maneuver initiated by the pilot to align the aircraft with a runway for landing when a straight-in landing from an instrument approach is not possible or desirable, like the VOR-A to Fullerton Muni (KFUL)

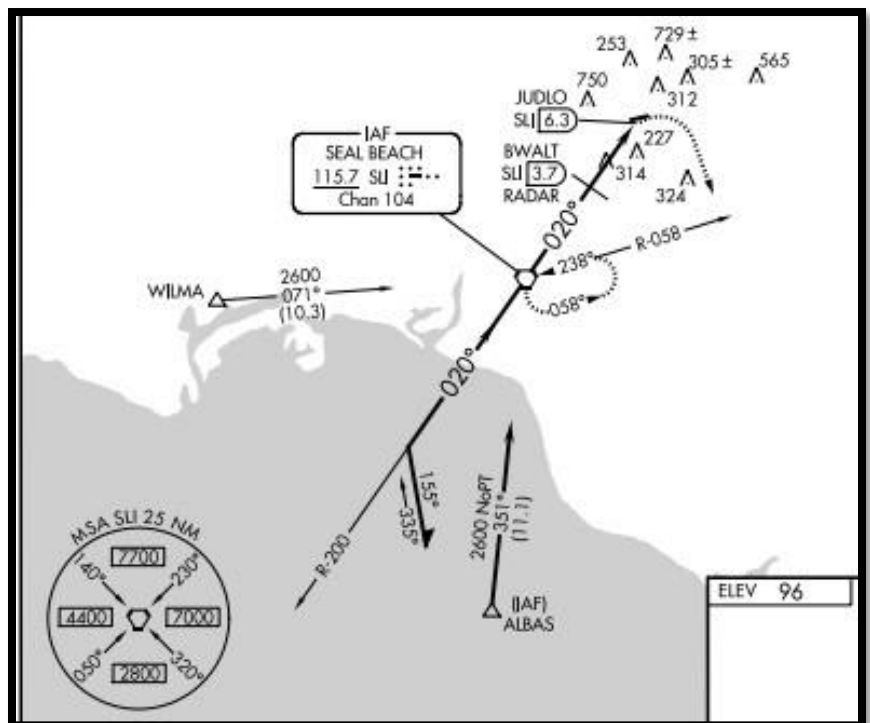

VOR or GPS-A, Corona, CA (KAJO)

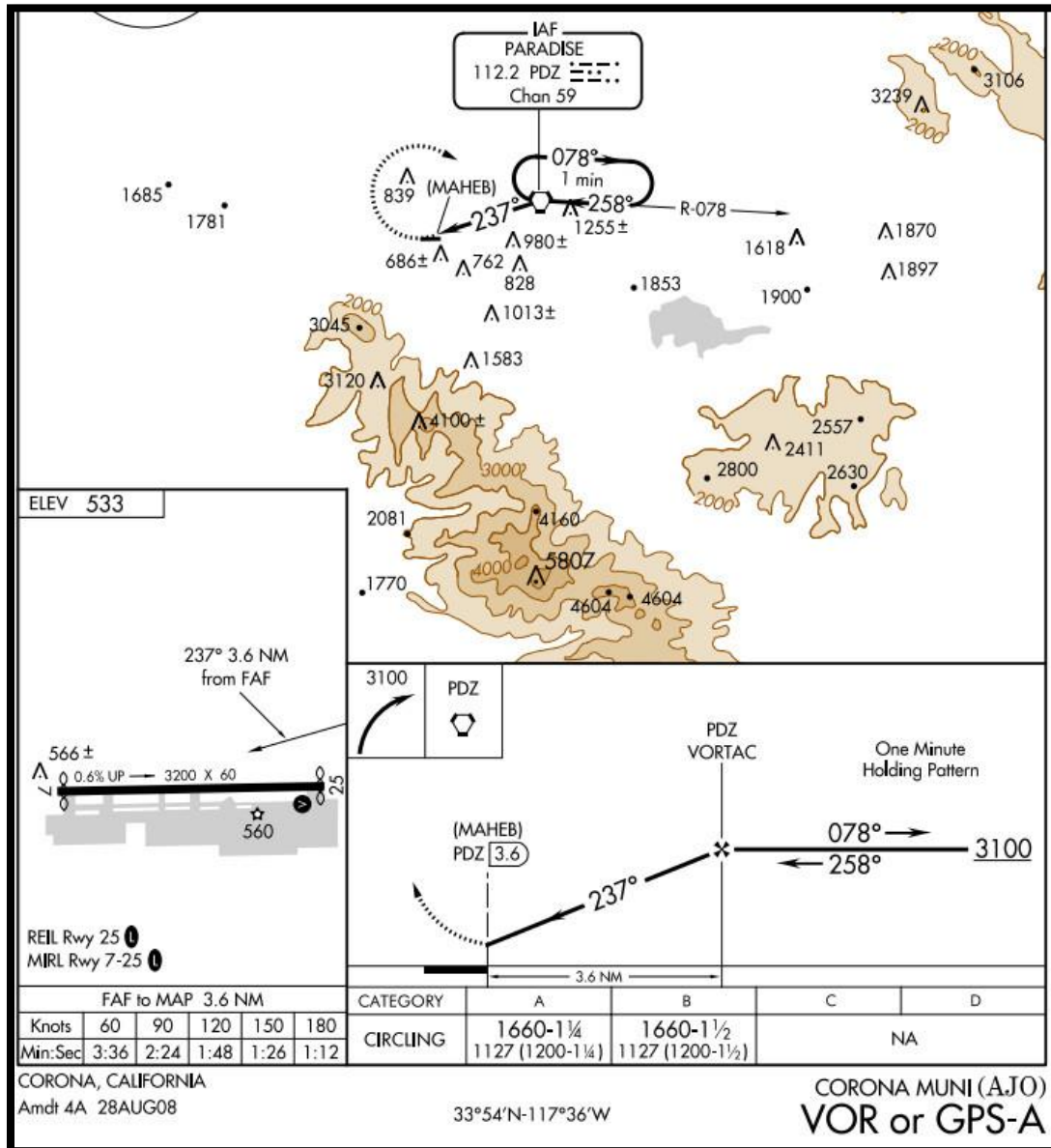

If the final approach exceeds the runway alignment factor of 30°, or 15° in the case of a GPS approach, this mandates the design of a circling approach. (AIM 5-4-20)

The VOR or GPS-A to Corona (KAJO), shown above, has a final approach course of 237° to Runway 25. That's only about 15° off, and yet it's a circling approach. **WHY?** Look at the profile view. A straight-in approach would require a descent from 3,100' MSL to the 533' MDA in 3.6 nm. If you never leveled off at the MDA, and dove for the end of the runway, you'd need to lose 2,567' and you'd need to lose it *FAST* . . . at over 700 feet per mile! That's a 7° glide path . . . way too steep for a straight in approach.

After the FAF, descend to the MDA as usual. Upon making visual contact with the runway, and with reasonable certainty that you will be able to remain in contact, you are free to maneuver / circle and align with the landing runway. This is typically a modified visual traffic pattern. You must not descend below the Minimum Descent Altitude until you are in a position from which a descent to a landing on the intended runway can be made at a normal rate of descent using normal maneuvers. The following basic rules apply:

1. Maneuver the shortest path to the base or downwind leg, as appropriate, considering existing weather conditions. There is no restriction from passing over the airport or other runways.
2. It should be recognized that circling maneuvers may be made while VFR or other flying is in progress at the airport. Consider a standard left turn **or follow the controller's instructions.**
3. At airports without a control tower, it may be desirable to fly over the airport to observe wind and turn indicators and other traffic, which may be on the runway or flying in the vicinity of the airport.

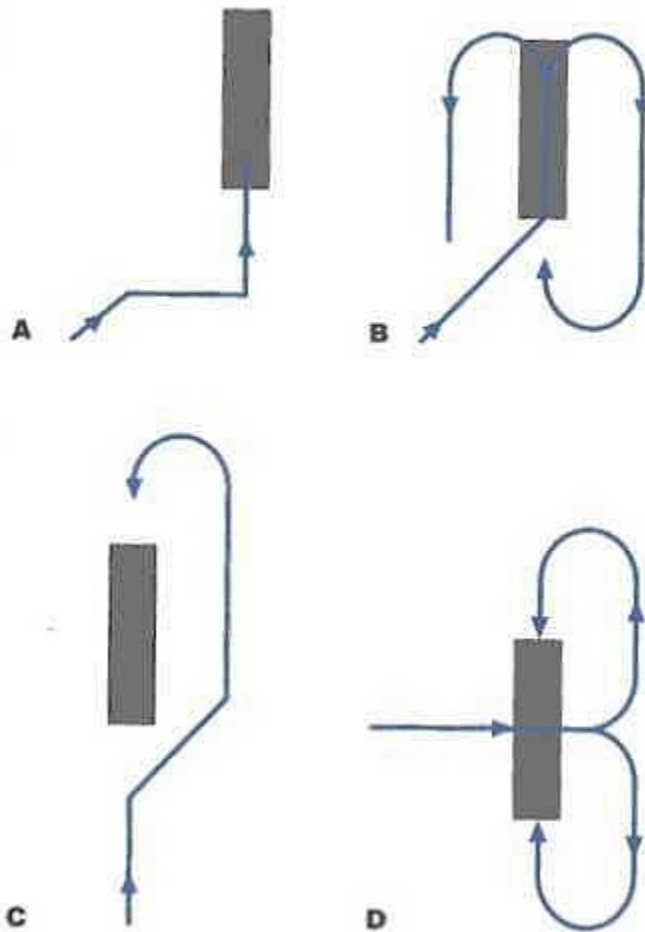

Aircraft Categories

These are based on 1.3 times your aircraft's V_{so} or stall speed. Find your aircraft's 1.3 V_{so} in the chart below and that is your category. Use that column in the IAP minima table to find your DH or MDA. While circling, stay within the area defined by circles centered on the runway thresholds with a radius as shown in the table.

If it is necessary to maneuver at a speed higher than your approach category, use the category that corresponds to that speed and apply those approach higher category minimums.

Category	Maneuver Speed	Circling Radii
A	0 - 90 knots	1.3 miles
B	91 - 120 knots	1.5 miles
C	121 - 140 knots	1.7 miles
D	141 - 165 knots	2.3 miles
E	166 knots or more	4.5 miles

If your V_{so} is 69:

$69 \times 1.3 = 90$ Maneuvering Speed – Category A

Sidestep

ATC may authorize a sidestep maneuver to either one of two parallel runways that are separated by 1,200 feet or less, followed by a straight-in landing on the adjacent runway. Aircraft executing a sidestep maneuver will be cleared for a specified non-precision approach and landing on the adjacent parallel runway. For example, "Cleared ILS runway 7 left approach, sidestep to runway 7 right." Pilots are expected to commence the sidestep maneuver as soon as possible after the runway or runway environment is in sight. Landing minimums to the adjacent runway will be based on non-precision criteria and therefore higher than the precision minimums to the primary runway. However, landing minimums to the adjacent runway will normally be lower than the published circling minimums. When in doubt, use circling minimums.

Standard Circling Approach Maneuvering Radius

If you are making a 30° bank turn at 8,000' MSL and holding 100 knots IAS, you're going faster and cover a larger radius than if you do the same thing down at 1,000' MSL.

If a Circling approach was developed prior to late 2012, it does not account for the larger turn radii required at higher altitudes and the excessive bank angle required to stay within the prescribed area. These approaches do not account for wind and they don't provide for a stabilized approach, starting at least 500 feet above the runway.

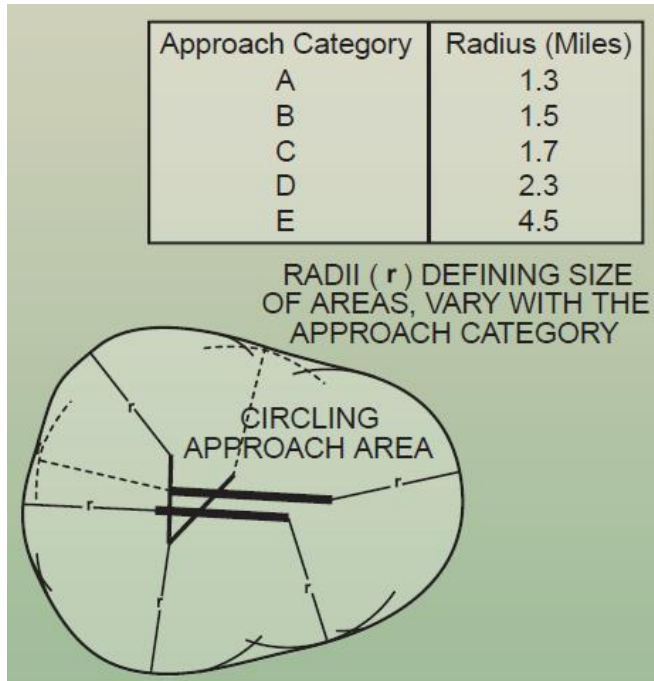

Note: These turning radii are in Statute Miles **(SM)**

Pre-2012 Criteria

Old Circling Approach Maneuvering Radius (nm)

Circling MDA in feet MSL	Approach Category and Circling Radius (NM)				
	CAT A	CAT B	CAT C	CAT D	CAT E
All Altitudes	1.3	1.5	1.7	2.3	4.5

NEW Terminal Instrument Procedures (TERPS) circling approaches designed after 2012, consider altitude and assume a 25 kt wind.

Circling MDA in feet MSL	Approach Category and Circling Radius (NM)				
	CAT A	CAT B	CAT C	CAT D	CAT E
1000 or less	1.3	1.7	2.7	3.6	4.5
1001 – 3000	1.3	1.8	2.8	3.7	4.6
3001 – 5000	1.3	1.8	2.9	3.8	4.8
5001 – 7000	1.3	1.9	3.0	4.0	5.0
7001 – 9000	1.4	2.0	3.2	4.2	5.3
9001 & Above	1.4	2.1	3.3	4.4	5.5

Approaches designed after 2012 – Annotation

AeroNav approach charts are annotated with an “Inverse C” symbol to denote the new expanded circling approach maneuvering airspace radii.

 CIRCLING	1460-1 600 (600-1)	1480-1 620 (700-1)
--	-----------------------	-----------------------

 **JEPPESSEN** uses an “Inverse C” diamond
A BOEING COMPANY

CIRCLE-TO-LAND	
Circling not authorized East of Rwy 3R/21L.	
Max Kts.	MDA(H)
90	1580' (495') - 1
120	1580' (495') - 1 1/2
140	1580' (495') - 1 1/2
165	1640' (555') - 2

*Circling Missed Approach

Start a climb toward the landing runway, and then follow the Missed Approach Procedure.

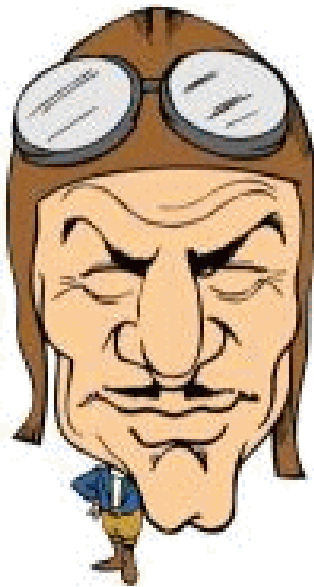

Circling Travel Tips

- *The circling radius for a category A aircraft is generally 1.3 nm, so do not wander too far from the runway, and never turn your back to the runway.*
- *If you find yourself in IMC conditions after initiating a circling maneuver in VMC, execute a Missed Approach.*
- *Fly the circling approach as close to pattern altitude as possible. Circling minimums only provide 300 feet of obstacle clearance.*

Approach Lighting Systems

- **ALSF-1 and ALSF-2:** Both have Sequenced Flashing Lights, commonly known as “the rabbit”. Both systems are 2,400’ to 3,000’ long.
- ALSF-1 has red terminating bars. →

Sequenced
flashing lights, or
“the Rabbit”.

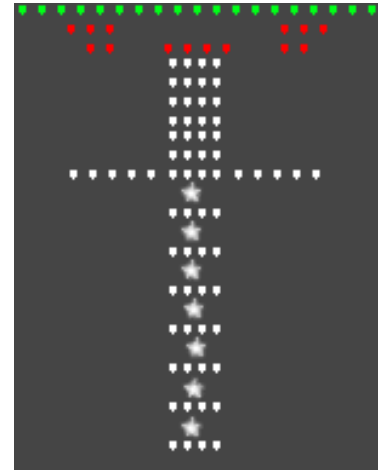

- ALSF-2 has red side row bars →

Sequenced
flashing lights, or
“the Rabbit”.

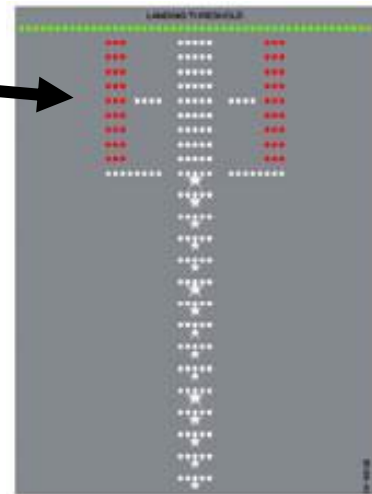

- MALSR & MALSF: Medium-intensity Approach Lighting Systems. Both have a short “rabbit” and are 1,400’ long (1/4 mile+)
- SALS: Simple Approach Lighting System.
- SSALS: Simplified Short Approach Lighting System.
- SSALR & SSALF: Simplified Short Approach Lighting System with a short “rabbit”. 1,400’ long (1/4 mile+)

Why is knowing about approach lighting important?

When the visibility is low and you are at minimums, the approach lights may be the only thing that you can see. Those lights will permit you to continue the approach to 100' above the runway, where you will either land (if you see the runway) or execute a missed approach.

Approach, Part 91 Operations

If the weather conditions are reported to be below minimums, you can still try the approach, just to “take a look”. However, you must never descend below minimums, unless *FAR 91.175* criteria are met

Descending below the MDA/DH/DA (FAR 91.175)

You cannot descend below the MDA/DH/DA unless:

- You are in a position to land on the intended runway using a normal rate of descent and normal maneuvers. (Part 121 & 135 operators must land in the touchdown zone).
- You determine that flight visibility is at or above that which is required to complete the approach.

If the approach lights are in sight, you may descend to 100 feet above the Touchdown Zone Elevation (TDZE). ***You may descend lower than 100 feet above the***

TDZE, if either of these are clearly visible:

- The Red Terminating Bars (ALSF 1 system)
- The Red Side Row Bars (ALSF 2 system)



In the absence of an approach lighting system, you may descend below the MDA/DH/DA and land if any of the following are in sight:

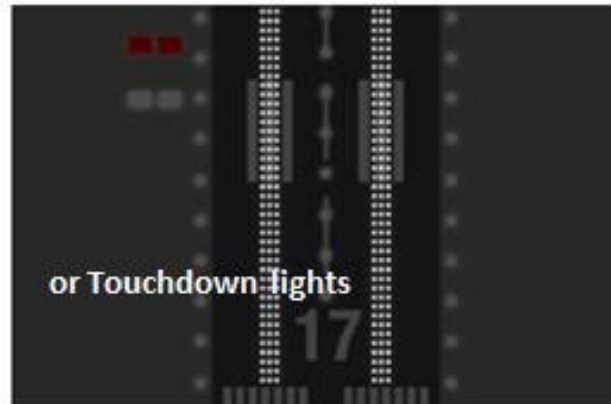
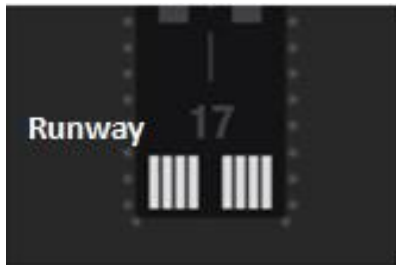
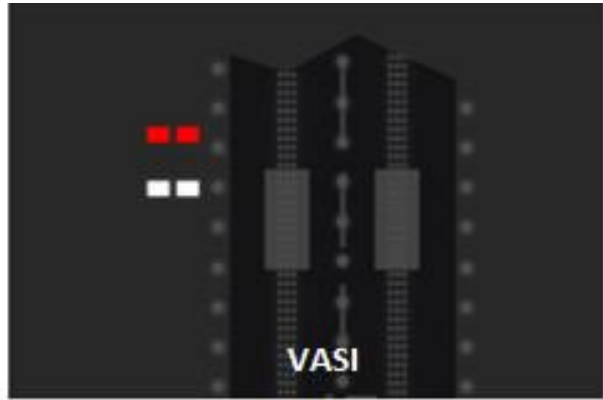

RVR (feet)	Visibility (Statute Miles)	RVR (feet)	Visibility (Statute Miles)
1,600	$\frac{1}{4}$	4,500	$\frac{7}{8}$
2,400	$\frac{1}{2}$	5,000	1
3,200	$\frac{5}{8}$	6,000	$1 \frac{1}{4}$
4,000	$\frac{3}{4}$		



Fly Visual Approaches

HAILEY, IDAHO

AL-6239 (FAA)

16315

NDB/DME HLE 220	APP CRS 335°	Rwy Idg TDZE N/A	N/A
Chan 25 (108.8)		Apt Elev 5320	

NDB/DME-A
FRIEDMAN MEMORIAL (SUN)

⚠ NA Circling NA NE of Rwy 13-31. Visibility reduction by helicopters NA. When control tower closed, procedure not authorized. Occasional ADF needle swings away from the final approach course are to be expected north of missed approach point. Procedure NA at night.

MISSED APPROACH: Climbing left turn to 8800 direct HLE NDB and hold.

ATIS 128.225	SALT LAKE CENTER 118.05 353.0	HAILEY TOWER* 125.6 (CTAF)	GND CON 121.7	UNICOM 122.95
------------------------	---	--------------------------------------	-------------------------	-------------------------

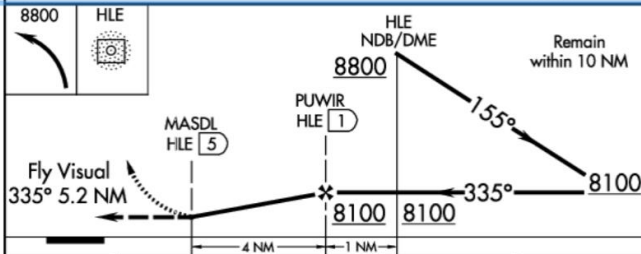
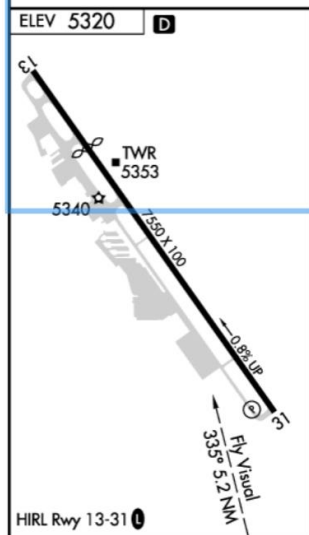
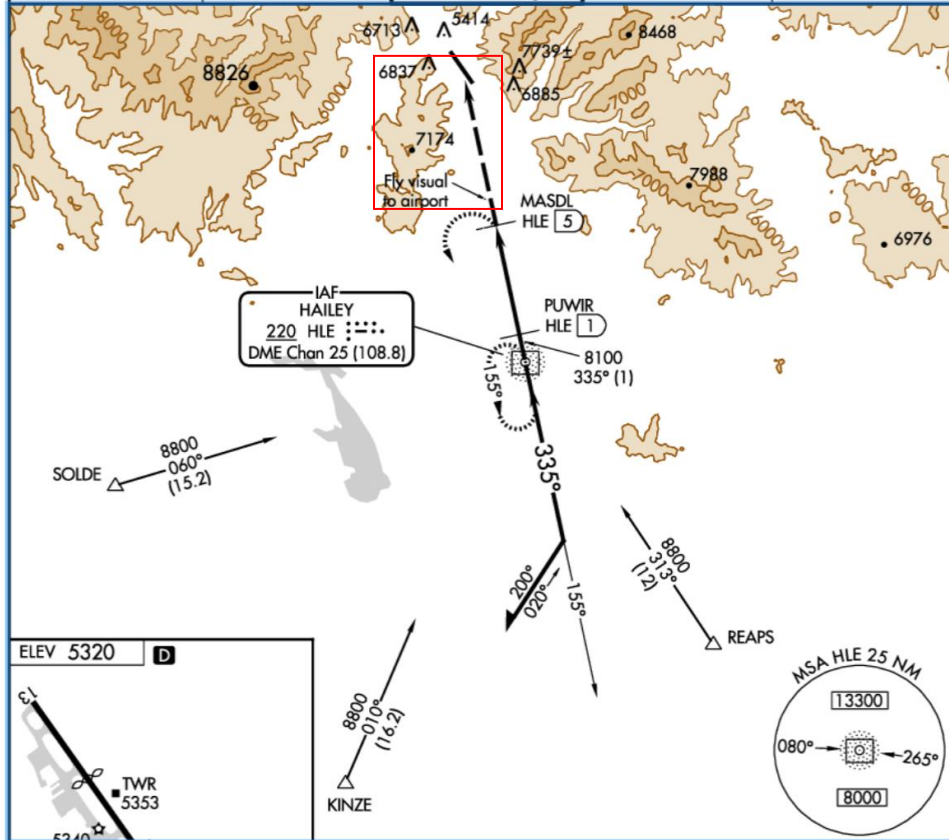

CATEGORY	A	B	C	D
C CIRCLING	8040-5	2720 (2800-5)		NA

HAILEY, IDAHO
Amdt 1 06FEB14

43°30'N-114°18'W

FRIEDMAN MEMORIAL (SUN)
NDB/DME-A

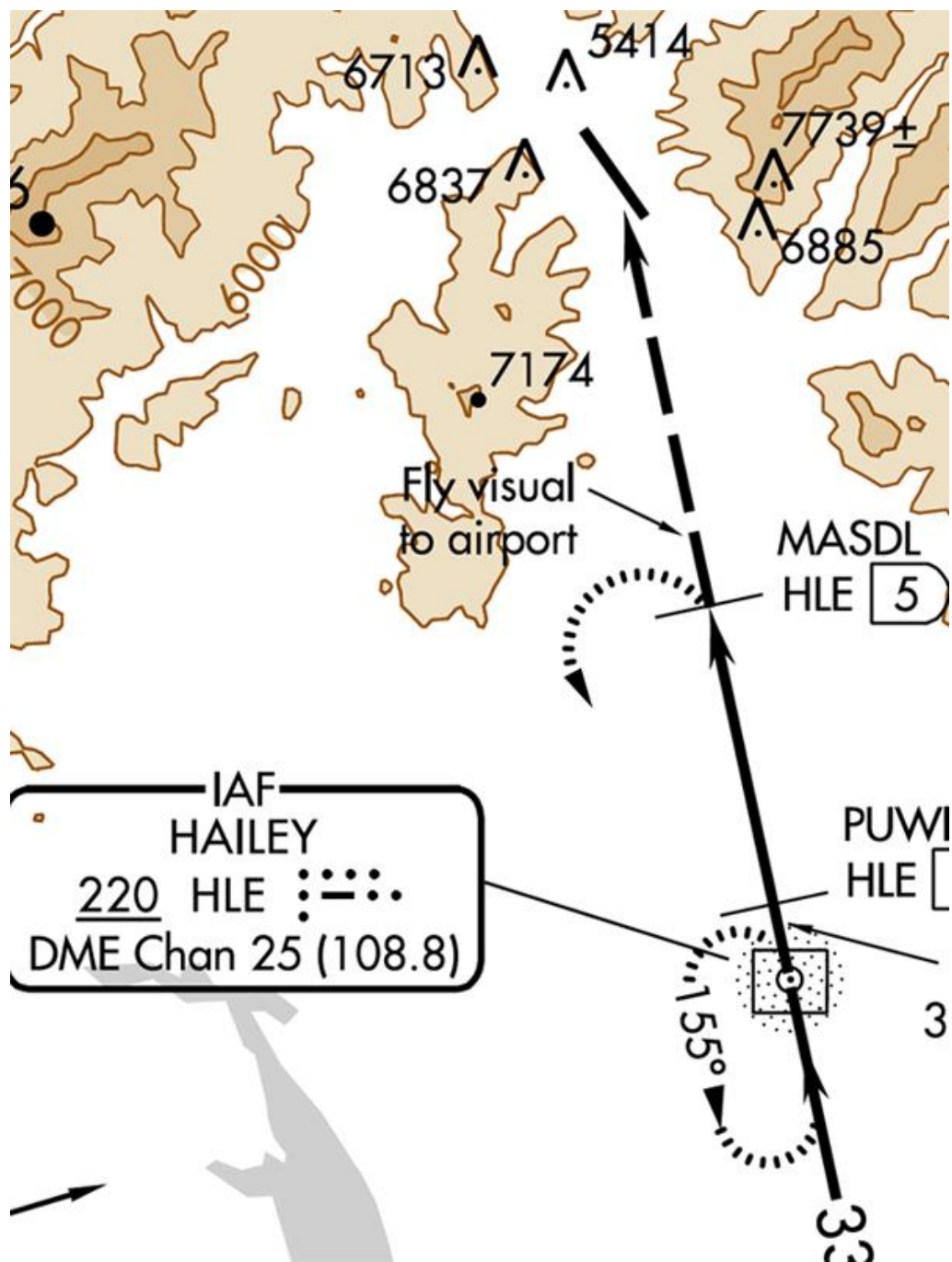

When you begin the “Fly Visual” portion of the procedure, altitude is left to your discretion, but you must proceed to the airport while maintaining visual contact with the ground. Ref. [AIM 5-4-5 \(g\)\(1\)](#).

What you should know about Fly Visual Segments

You don't need to have the airport in sight before you descend below the MDA/DA.

Fly the Fly Visual Segment as a dead-reckoning course.

The flight visibility must not be less than that shown on the approach chart for the category of aircraft.

You must remain clear of clouds and proceed to the airport maintaining visual contact with the ground.

The pilot must visually avoid obstacles while flying the segment.

The visibility required for the approach can be less than the length of the Fly Visual Segment. Therefore, you can continue beyond the missed approach point without the runway environment in sight, provided you have the required flight visibility.

Altitude on the Fly Visual Segment is at the discretion of the pilot, so he or she should visually acquire and avoid obstacles.

If you lose ground contact after passing BISAC and decide to execute a missed approach, there is no Missed Approach Procedure. Before flying the approach, you should pre-plan climb out options based on the aircraft performance and terrain features.

The terrain is depicted in contours, spot elevations, and gradient tints of brown when an airport meets the following criteria:

- The terrain within the plan view exceeds 4,000 feet above the airport elevation, or
- The terrain within 6 NM of the airport rises to at least 2,000 feet above the airport elevation.

Why build such an approach?

In many cases, the terrain in the missed approach area would necessitate unreasonably high minimums if the MAP were in its normal position. By displacing the MAP a few miles, the designers can build a missed approach segment without problems with terrain.

Following the missed approach point (in this case, MASDL), the standard required visual references of [FAR 91.175](#) do not apply, so there is no expectation that the pilot have the runway or airport environment in sight. Instead, the pilot must only have at least the flight visibility specified for the procedure, remain clear of clouds and remain in visual contact with the ground. Ref. [AIM 5-4-5 \(g\)](#).

The obstacle clearance for a missed approach procedure assumes that the missed approach begins at the missed approach point. If you proceed beyond the missed approach point along the “Fly Visual” portion of the procedure, there is no longer any guaranteed obstacle protection. In this case, obstacle clearance is your responsibility, and the AIM recommends “... the pilot should have preplanned climb out options based on aircraft performance and terrain features.” Ref. [AIM 5-4-5 \(g\)\(2\)](#).

Visual Descent Point (VDP)

The Missed Approach Point or MAP is never located where a pilot could start a nice 3° descent for landing. It is more likely to be located at the runway threshold.

That is why the FAA came up with the **Visual Descent Point**, or **VDP**. This lets you decide if you want to initiate a missed approach before you reach the MAP. The VDP allows a 3° descent angle, (300 feet per mile), to the landing zone.

If you can see the runway at the VDP, you may start a descent to the runway.

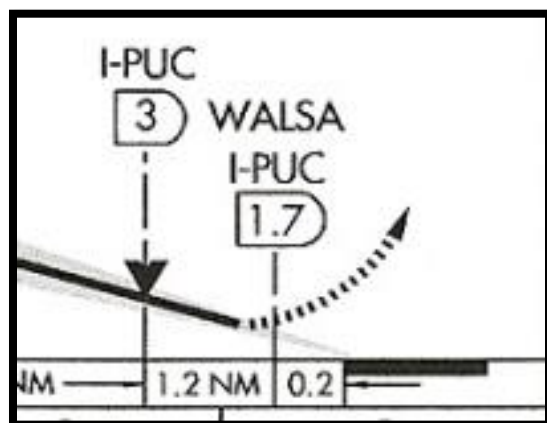

Reference this ILS/LOC DME, RWY 36 at KPUC:

The LOC’s VDP has been established at I-PUC’s 3 DME, which is **1.4** miles from the end of the runway.

At 1.4 miles, and at the LOC approach’s MDA – 6240, that’s **377’** above the runway threshold altitude.

S-LOC 36	6240-1 377 (300-1)
----------	--------------------

The Math

$\frac{377}{1.4} = 2.69^\circ$ angle of descent or 269 feet per

If you delayed your descent 2/10 of a mile past the VDP, you would be 1.2 miles from the runway end, still allowing for a very comfortable 3.14° descent angle or 314 feet per mile.

$\frac{377}{1.2} = 3.14^\circ$ angle of descent or 314 feet per

To convert a 3° glide slope descent into feet per minute, glance at the GPS's ground speed and multiply that number by 5. For example:

120 knots ground speed x **5** = **600** feet per minute.



No Published VDP

If you have DME or a GPS, you can figure your own VDP.

Divide the approach procedure's height above touchdown (HAT) by a descent gradient of 3° (300 feet per nautical mile).

Example for a HAT of 653 feet:

$$\frac{653}{300} = 2.17 \text{ VDP}$$

Visual Descent Angles (VDAs)

VDAs appear on some non-precision approaches for information purposes only. VDAs establish a stabilized descent from the FAF or step-down fix, meeting the VDP at the MDA, where the pilot, (if the runway environment is spotted), can safely land.

Reference the Oxnard (KOXR) VOR RWY 25 approach, the **Visual Descent Angle (VDA)**, depicted between the FAF and the MAP, is **3.37°** .

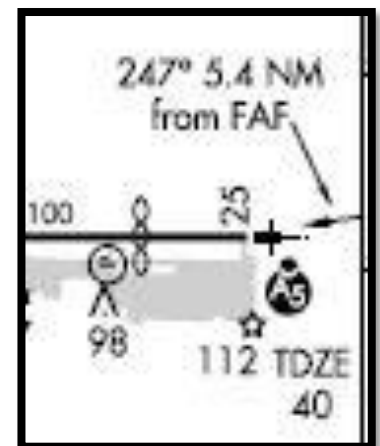
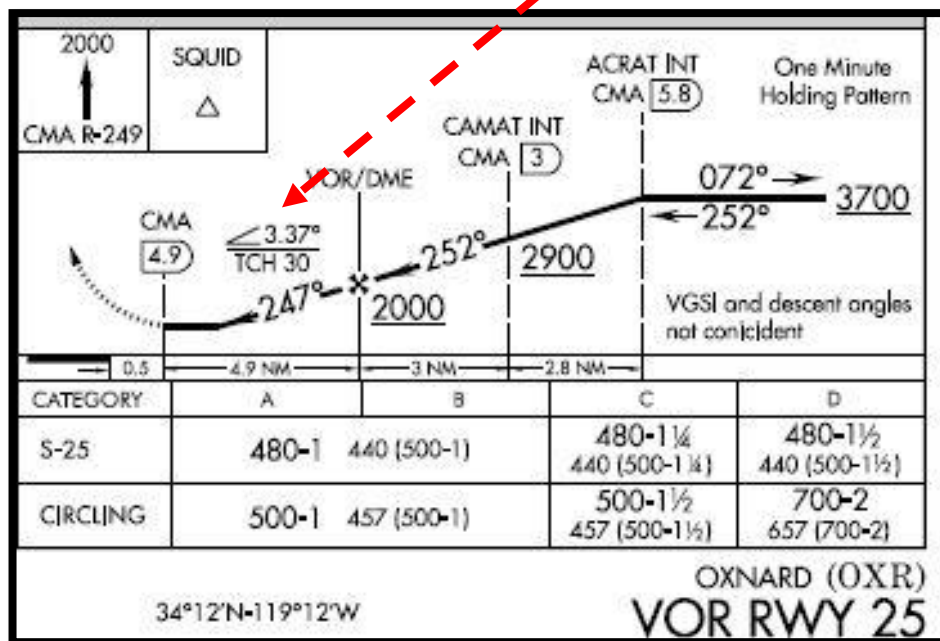

Visual Descent Angles (VDAs) continued

Drop the decimal point from the VDA to convert the 3.37° angle of descent to **337 feet per nautical mile**.



- Convert the Ground Speed into miles per minute. If the anticipated GS is 120, that's the same as 2 miles per minute. ($120/60 = 2$).
 - Multiply miles per minute by the number of feet per nautical mile required in the descent.
- $2 \times 337 =$ a descent rate of **674** feet per minute.



ILS Frequency Sharing

Some airports have an ILS approach to both ends of the runway. Detroit's Metro Airport (KDTW) has ILS approaches to both 4R and 22L. Both ILS frequencies are the same, (110.7), but the ILS identifications are different – I-DTW for 4R, and I-DWC for 22L. The different IDs mean each runway has its own LOC & GS transmitter.

Missed Approaches

After you have intercepted the approach's final approach course, set the Heading BUG, (if you have one), on the missed approach heading. Set the missed approach altitude in the altitude reminder, (if you have one), or write it down.

- **PRECISION APPROACH:** Execute Missed Approach when you reach the Decision Altitude (DA).
- **NON-PRECISION APPROACH:** Execute Missed Approach at the Missed Approach Point (MAP).
- If "missing" from a circling approach, climb towards the landing runway, then execute the published procedure.
- If you have made the decision to "go missed" before reaching the MAP, climb to the missed approach altitude, but continue the approach laterally to the MAP. Then, follow the published Missed Approach procedure.

When announcing to ATC that you are executing the "missed approach", include your intentions.

If you are practicing multiple instrument approaches, the tower or approach control may assign "**CLIMB OUT**" instructions that are contrary to the published missed approach procedure. In this case, when you initiate a "missed", the radio call is "**Climb out**", not "Missed approach."

Missed Approach Travel Tips

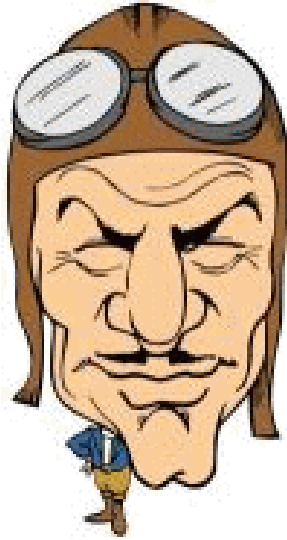

Don't try to memorize the entire missed approach procedure. Just remember the initial course or heading.

All Missed Approach Procedures begin with a climb, so initially:

- *Power UP,*
- *Nose UP,*
- *Clean UP, &*
- *Start the turn, if applicable*

Once safely in the climb, you can take a closer look at the procedure.

Unsuccessful Approach

If you have enough fuel to try another approach, and legally fly to your alternate, and you think you'll have a better chance on the next approach, then go for it. Proceed to your alternate, at or before you are short on fuel and ideas.

The Radar Instrument Approach – Precision Approach Radar (PAR) and Airport Surveillance Radar (ASR)

Details of the Radar Instrument Approaches are in the *AeroNav Terminal Procedures Publication*. They follow the

 **ALTERNATE MINS** section.



SAN CLEMENTE ISLAND NALF (KNUC), (FREDERICK SHERMAN FIELD), CA
 RADAR - (E) 127.05x 305.3x  (09071 USN) ELEV 184

	<u>RWY</u>	<u>GS/TCH/RPI</u>	<u>CAT</u>	<u>DH/</u> <u>MDA-VIS</u>	<u>HAT/</u> <u>HATh/</u> <u>HAA</u>	<u>CEIL-VIS</u>
PAR ¹	23	3.0°/40/939	ABCDE	434-1	250	(300-1)
PAR ¹	W/O GS 23		ABCDE	520-1¼	336	(400-1¼)
ASR ²	23		AB	780-1	596	(600-1)
			C	780-1½	596	(600-1½)
			D	780-1¾	596	(600-1¾)
			E	780-2	596	(600-2)
CIR ³	W/O GS All Rwy		A	540-1¼	356	(400-1¼)
			B	640-1¼	456	(500-1¼)
			C	640-1½	456	(500-1½)
			DE	740-2	556	(600-2)
CIR ³	All Rwy		AB	780-1	596	(600-1)
			C	780-1½	596	(600-1½)
			DE	780-2	596	(600-2)

¹No-NOTAM MP PAR 1800-2000Z++ Tue. ²No-NOTAM MP ASR 2000-2200Z++ Tue.

³Circling not authorized S of Rwy 5-23.

SW-3



Experience is the knowledge that enables you to recognize a mistake when you make it again.

Distances

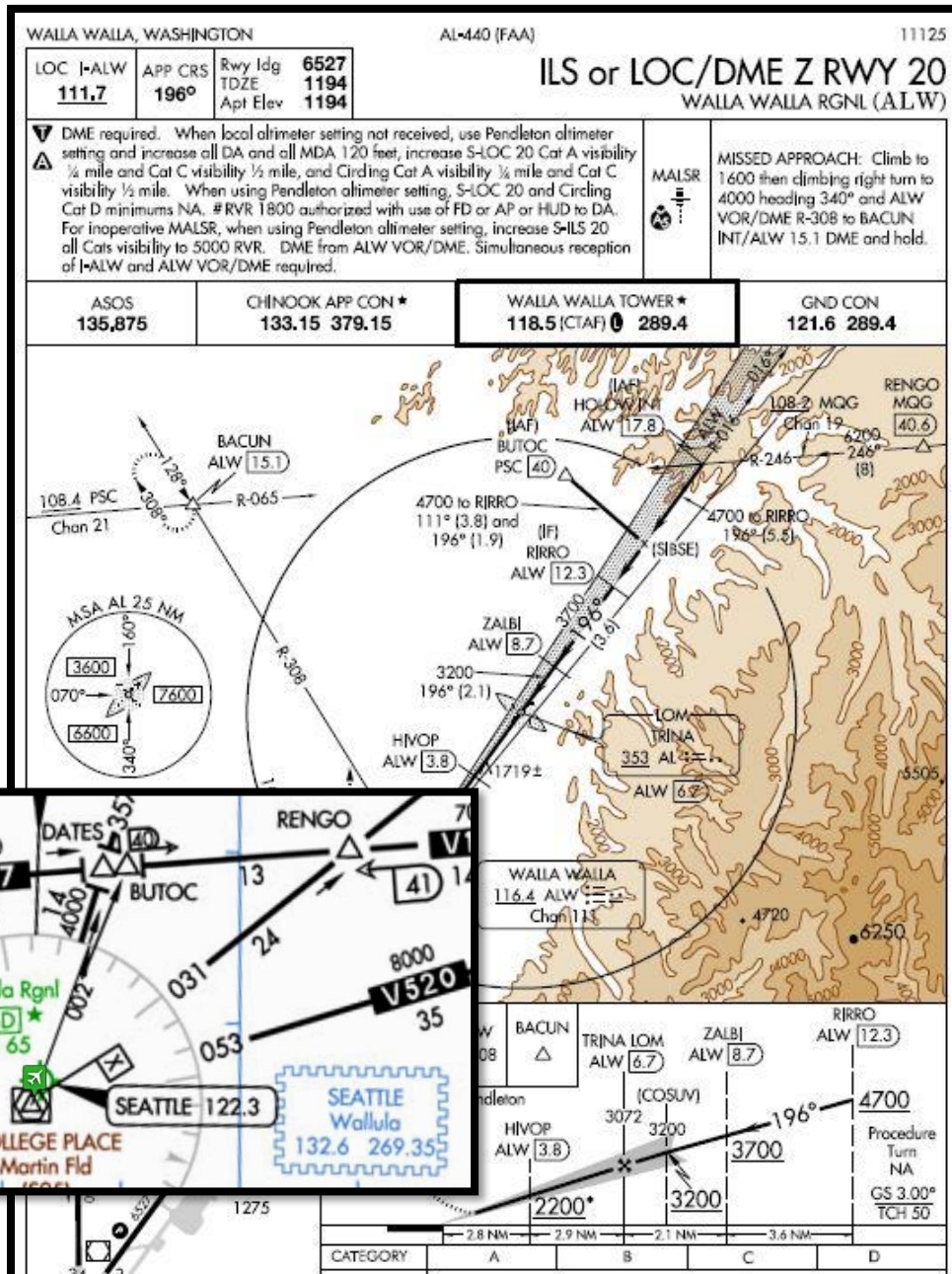

If you are on the Victor airway inbound to the ILS or LOC/DME Z RWY 20's IAF **RENGO**, the approach chart indicates that it's an 8-mile trip to the localizer (joining at the IAF HALOW), then another 5.5 to another Initial Fix - **RIRRO**.

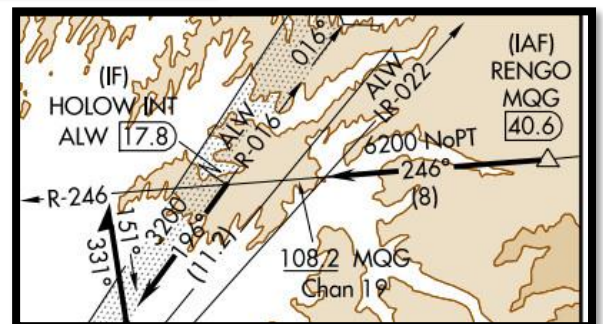

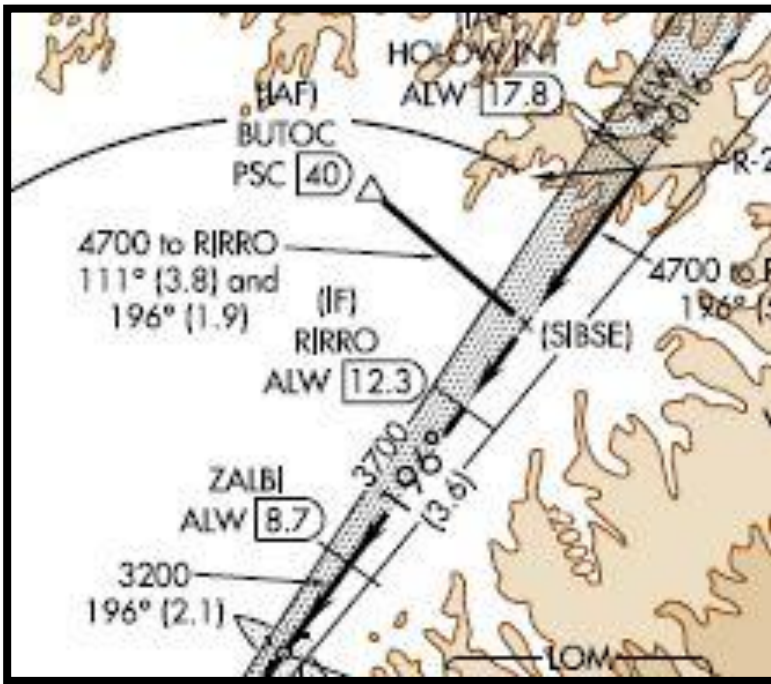

If you fly from **BUTOC** (IAF), to the localizer, the approach chart indicates two distances. The first distance, 3.8, is the distance to the localizer, joining at **SIBSE**. The second, 1.9, is the distance from the localizer and **SIBSE** to the IF - RIRRO

Using another approach, (ILS or LOC Y RWY 20), the approach chart indicates one distance from **DATES**: 8.5 from **DATES** to **TRINA** (LOM/IAF).

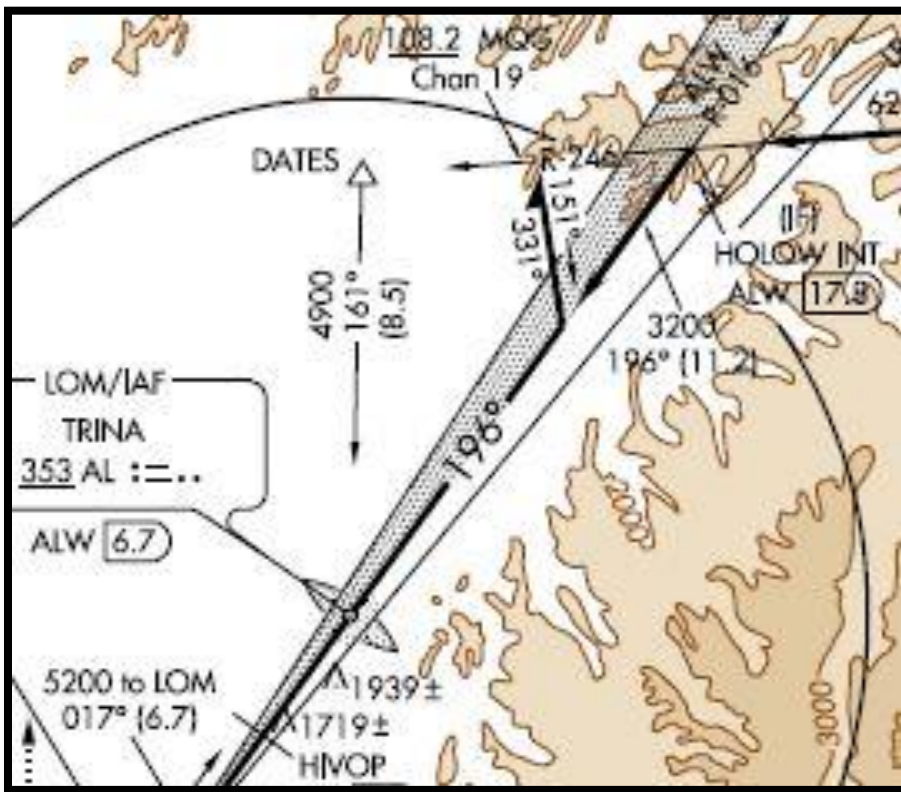

Conclusion

If two distances are given, the first is the distance to the inbound course/LOC interception. The second distance is from the course interception to the FAF/LOM or the IF.

GPS World

What's in a Name?

1. "What does the title of an approach chart indicate? For Example: LOC/DME RWY 18 or VOR RWY 20."
2. "On an approach chart, what does 'ADF Required' or 'DME Required' imply?"

Answer 1.: The title of the approach indicates **what equipment is required to fly the final approach segment (FAS).**

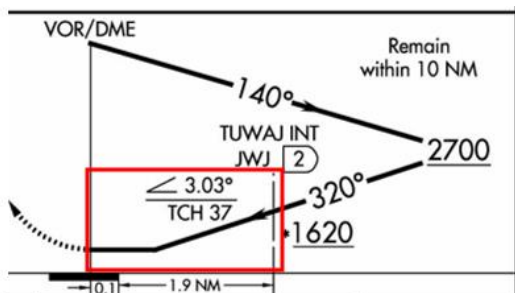

Answer 2.: Since the late 90s, the FAA has allowed us to substitute an IFR GPS for DME or ADF, **provided the fixes are in the GPS database.** "ADF required" usually indicates that an ADF is required to fly a transition to an initial approach fix (IAF) or it is required to fly the missed approach. (Got one? Does it work? Didn't think so...) No worries, an IFR GPS can be used in lieu of the ADF that you don't have.

GPS Overlay Approaches

GPS Overlay IAPs are being phased out and replaced by newer types of approach

procedures. The GPS Overlay initiative was something that the FAA did in the 1990s to add "or **GPS**" to the name of an already existing VOR, VOR/DME, VOR/DME RNAV or NDB approach. The designation allowed the use of certified GPS receivers to fly the entire approach, **including the final approach segment**, without referencing the VOR, VOR/DME or NDB ground signal.

VOR/DME RNAV or GPS RWY 16
AMELIA EARHART (K59)

NDB, VOR and TACAN approaches

You can find these approaches in your GPS procedure database.

However, if "GPS" is included in the **IAP title**, and it's used to reference and fly **the final approach segment**, you must have the applicable NAVAID (NDB, VOR or TACAN) installed in your airplane.

TACAN RWY 3L
YUMA MCAS/YUMA INTL (KNYL)

The FAA's Advisory Circular [AC 90-108](#)

"Use of Suitable Area Navigation (RNAV) Systems on Conventional Routes and Procedures" of March 3, 2011 (minor update in April 2015) states on pages 5/6, "An otherwise suitable RNAV system cannot be used for the following:

"...b. Substitution on a final approach Segment (FAS). Substitution for the NAVAID (for example VOR or NDB) providing lateral guidance for the [final approach segment] FAS."

Clarification from the AIM

In May 2016, a change was made in AIM 1-2-3. c Note #5:

“Use of a suitable RNAV [an IFR approved GPS] system as a means to navigate on the final approach segment of an instrument approach procedure based on VOR, TACAN or NDB signal is allowable. **The underlying NAVAID must be operational, and the NAVAID must be monitored for the final approach course alignment.**”

The Garmin GTN AFM supplement supports AIM:

“When using VOR or ADF receiver to fly the final approach segment of a VOR or NDB approach, **GPS may be the selected navigation source so long as the VOR or NDB station is operational and the signal is monitored for final approach segment alignment.**”

- The underlying ground-based NAVAID must be operational,
- It must be monitored; therefore, the relevant avionics receiver must be installed in your aircraft and it must be functional.
 - In the case of VOR, this shouldn't be a problem, but it's more of a problem for NDB approaches since working panel mounted ADFs are uncommon.



Non-Overlay Approach

The need to “monitor” the VOR or NDB is more than just listening to the ident signal. You need to **confirm final course alignment**. For a VOR, there are two ways:

- In a glass PFD, tune the VOR and assign one of the **bearing pointers** to the VOR.
- In a round-dial panel:
 - Assign one of the VOR/LOC heads to the VOR.
 - ADFs need a bearing pointer, either external or built in.



GPS & RAIM (**R**eciever **A**utonomous

Integrity **M**onitoring) (AIM 1-1-19)

The GPS receiver verifies the integrity or usability of the constellation of GPS satellite signals to determine if a satellite is providing corrupt info.



A RAIM failure annunciates **two minutes after** the GPS integrity monitoring cannot “see” at least **5 satellites**, or **two minutes after** the RAIM integrity monitor detects a potential error.



RAIM Warnings on Approach – Execute a Missed Approach if:

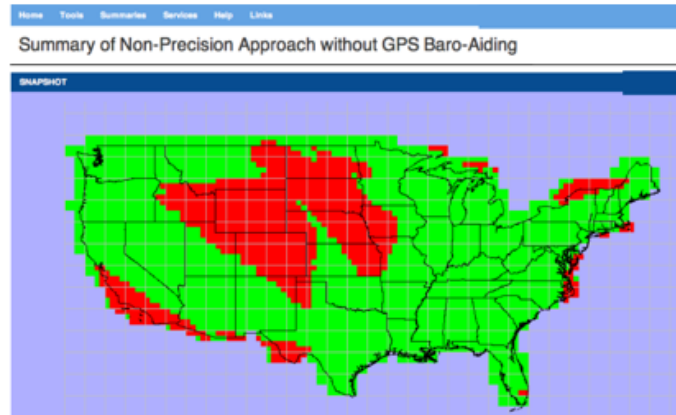

- A RAIM warning appears.
- **You have a non-WAAS GPS**, such as a Garmin 530/430, and within **2 nm** of the final approach fix (FAF), it does not switch from **TERM** to **APR** or **0.3^{nm}**
- **You have a WASS GPS**, such as a Garmin GNS 530W/430W or GTN 650/750, and within **2 nm** of the final approach fix (FAF), it doesn't switch from **TERM** to either **LNAV**, **LPV**, **L/NAV**, or **LNAV+V**

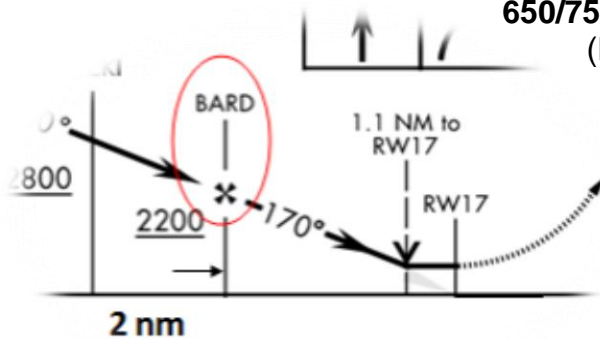

Dead Reckoning Mode (DR) is a “Stopgap”

“While in Enroute or Oceanic phase of flight, if the system detects an invalid GPS solution or is unable to calculate a GPS position, the system automatically reverts to Dead Reckoning (DR) Mode. In DR Mode, the system uses its last-known position combined with continuously updated airspeed and heading data (when available) to calculate and display the aircraft’s current estimated position.”

In DR Mode, all GPS-derived data (distance/bearings to waypoints, groundspeed, direct track, track, estimated time enroute, etc.) is computed based upon an estimated position and may become increasingly unreliable. Thus, it must not be used as a sole

means of navigation. The relative inaccuracy of DR Mode is compounded by **changes in wind speed and/or wind direction.**

DR Mode is a stopgap, giving you GPS-like guidance **for up to 20 minutes** after a GPS failure or outage. The CDI deviation bar will remain displayed, and the autopilot will remain coupled. 20 minutes is enough time to set up other navigation equipment, and to ponder your options, if the GPS-derived position data isn't restored quickly—or at all.

GPS Waypoints in SIDs, STARs and Approaches

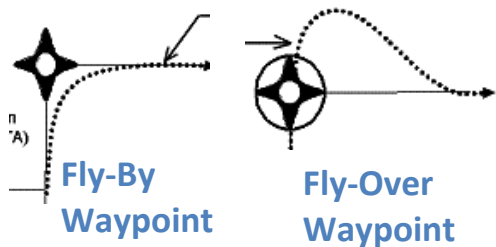

If the fix is circled, it is a FLY-OVER fix. You must fly over the fix before turning to the new course.

GPS and Database Limitations

- GPS systems are so good that we often forget that paper or electronic flight bag (EFB) enroute charts, as well as departure, arrival and approach charts are still required and necessary for flight. Pilots need to verify – between the GPS and the paper chart or electronic flight bag chart – that all the waypoints or NAVAIDs are in the correct location.
- Not all instrument flight procedures can be coded into a SID, STAR, or approach procedure. “Uncodeable” procedures, like those containing radar vectors or complicated contingent instructions are not included in the database.
- Step-down fixes between the FAF/IF and MAP are not included in the database because not all systems can handle their inclusion. Your database may not include every leg or segment of a procedure.
- If you can't refer to an approach chart, you are not authorized to fly it.
- You should not fly approaches to private airports, or use helicopter approaches, unless of course, you're flying a helicopter.

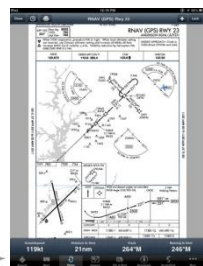
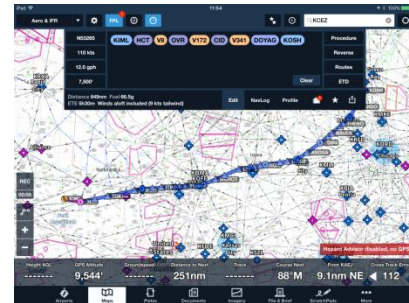

When passing each RNAV waypoint, think – *SOURCE, FORCE, and COURSE*

- **SOURCE** — Verify that the correct *SOURCE* is being used for navigation, such as GPS or VLOC.
- **FORCE** — Verify that the correct GPS Mode is displayed:
 - Enroute (“ENR”),
 - Terminal (“TERM”), or
 - The final approach sensitivity annunciation:
 - **Non-WAAS 430/530 –**
 - “APR”, or
 - “0.3ⁿm” (ILS/LOC approaches)
 - **430W/530W –**
 - “LNAV”,
 - “LPV”,
 - “L/VNAV”, or
 - “LNAV+V”
- **COURSE** — Put the proper *course* in the CDI/HSI. Do not wait to be prompted by the GPS.

Watching the WAAS and Non-WAAS



Watching the GNS 430W/530W can be fascinating. However, you are still responsible for ensuring that holding patterns do not exceed the required time or distance, and that a procedure turn or holding in lieu of a procedure turn does not exceed the charted distance or time.

Enroute & Terminal Modes

Within 30 nm of the destination, the GNS 430 / 530 will switch from the **ENRoute** mode to the **TERM**inal mode.

This results in a gradual GPS CDI scale transition from 5.0 nm to 1.0 nm – for a full-scale deflection.



Approach: CDI Scale Transitions

GPS Approach, 430W/530W: If the FAF is the TO waypoint, and you are within 45° of the final approach course, the “TERM” annunciation changes to “LNAV”, “LPV”, “L/VNAV”, or “LNAV+V”.

GPS Approach, 430/530 non-WAAS: When within 2 nm of the FAF, the “TERM” annunciation changes to “APR”.

VOR, LOC/ILS (ground signals)

As you approach the FAF:

The “TERM” annunciation in the lower left corner of the screen will change to:

- **430W/530W:** “LNAV”.
- **430/530 non-WAAS:** “0.3^{nm}”.

Both “LNAV” and “0.3^{nm}” mean that the GPS CDI scale is transitioning from 1.0 nm to 0.3 nm full scale deflection. You can also see it depicted on the Default NAV screen, (next page).



ILS Approach: The scale transition does not affect the CDI or HSI. It applies only to the

CDI on the default NAV Page. The aircraft’s CDI/HSI is coupled to the VOR or LOC receiver.



ILS Approaches

Reference the ILS 21 at Prescott, AZ (KPRC).

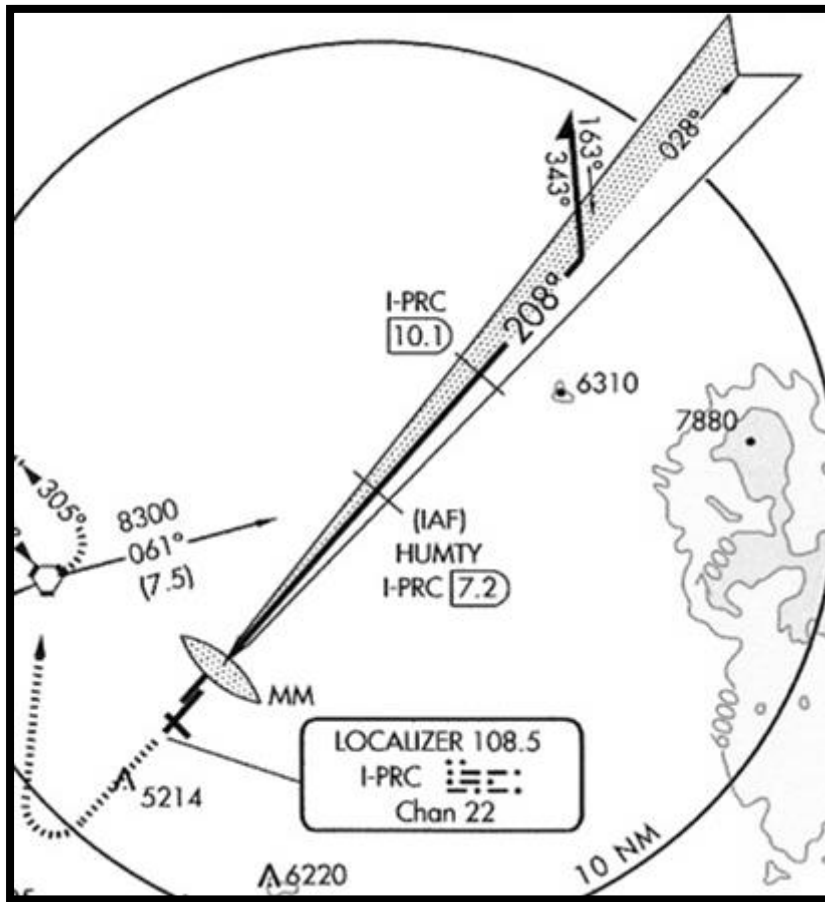

Prior to crossing the **IAF** – HUMTY, ensure that the Localizer frequency, 108.5, is in the active spot.

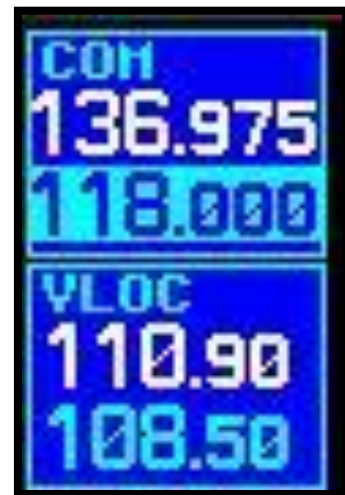

ILS Approaches and Auto Switching

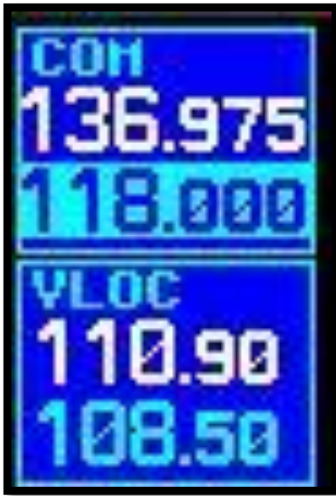

If the LOC/ILS frequency is in the active spot, CDI/HSI coupling will automatically switch from the GPS receiver to the VLOC receiver as you complete the procedure turn inbound.

If you fail to switch the ILS frequency to the active frequency spot, a “**SELECT APPROPRIATE FREQUENCY FOR APPROACH**” message will appear within 3.0 nm of the FAF (Garmin 430/530), or 2.0 nm of the FAF (Garmin 430W/530W).

If within 2.0 nm of the FAF, and auto switching has not occurred, you must manually press the **CDI** key.



*The Automatic Switching feature works for ILS, SDF and LDA approaches, but **not** for LOC Backcourses.*

Vectors to Final – Don't do it! You'll be sorry

If you select an approach and choose the “**VECTORS TO FINAL**” option, this generates an extended line from the runway. The only “fixes” depicted are the runway and the final approach. However, don't do it 'cause it's a trap! If you do choose the GPS's “Vectors to Final” option, you can bet that ATC will clear you to a fix outside the FAF, and you'll be all over the place in the cockpit, trying to correct it.

Select a full procedure, and if the procedure includes holding or a procedure turn, you can clear (**CLR**) it from the Flight Plan page.

Z, Y, X, etc.

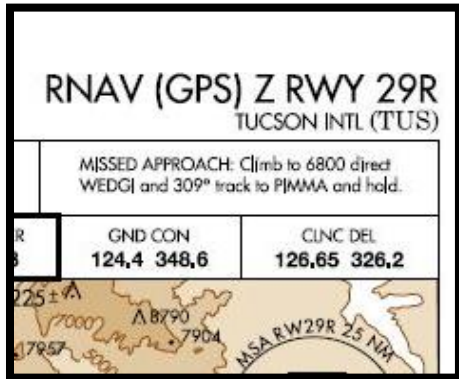

When multiple RNAV (GPS) approaches are published for the same runway, each approach is assigned a suffix from the end of the alphabet.

The approach with the lowest minimums receives the Z suffix, the next lowest gets Y, and so forth.

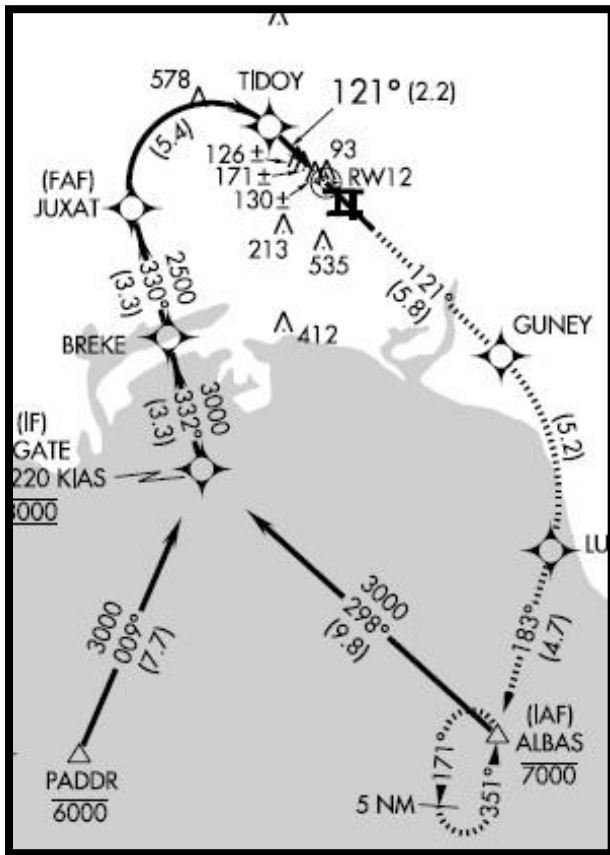
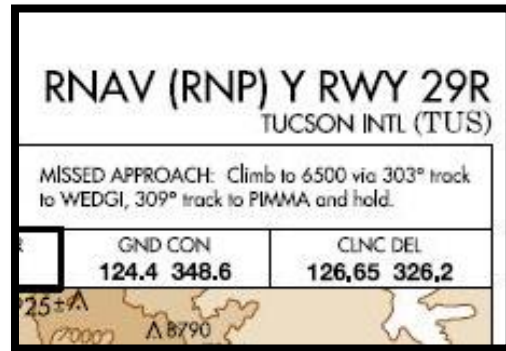

Required Navigation Performance (RNP)

RNAV (GPS) and RNP systems are fundamentally similar, but RNP approaches sometimes have curved legs and require on-board performance monitoring and alerting. These are Authorization Required (AR) approaches. This means the aircraft must be authorized and that crews flying RNP approaches must have specialized training. An airline pilot who is authorized to fly RNP in a A-320 cannot transfer that authority to his or her Cessna 310.

RF Legs (*Radius-to-Fix*)

Constant radius turns around a fix are referred to as *RF* legs (or Radius-to-Fix legs).

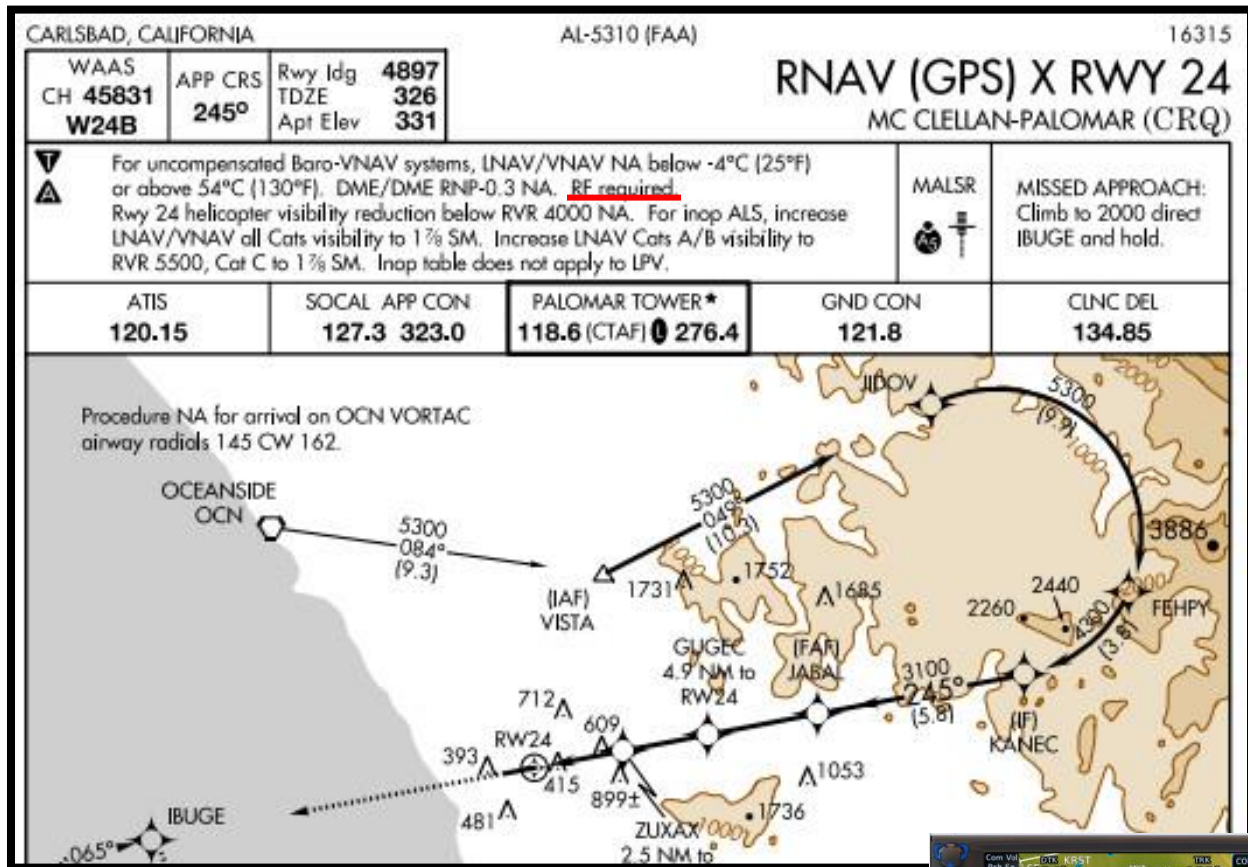

Consider the RNAV (GPS) X RWY 24 at Palomar ([CRQ](#)). When reading the fine print, we see that “RF Required” is indicated in the briefing box. RF, the curving portion of the approach, is from JIDOV to KANEC.

March 1, 2016, Garmin released system software 6.11 for the GTN series 650 & 750, which includes the ability to fly RF legs on approaches that are not classified as AR (Authorization Required) procedures, such as RNP approaches.

The Garmin GNS 430W & 530W) also meets the equipment performance and functional requirements to conduct *RF* legs subject to these limitations:

- 180 KIAS max on RF leg
- Procedures with RF legs must be flown using either a flight director or coupled to the autopilot.



WAAS and Non-WAAS GPS Minimums

LPV – Localizer Performance with Vertical Guidance

- Requires a WAAS GPS.
- LPV has a glide path.
- Use “LPV DA” approach minimums.

	1 NM	2.5 NM	1.7 NM	3 NM	3.2 NM
CATEGORY	A	B	C	D	
LPV DA		6104-1¼	291 (300-1¼)		
LNAV/VNAV DA		6152-1¼	339 (300-1¼)		
LNAV MDA	6260-1	447 (400-1)		6260-1¼	6260-1½



LNAV/VNAV – Lateral NAVigation / Vertical NAVigation

- LNAV/VNAV approaches were developed to accommodate an RNAV IAP with vertical guidance, usually provided by approach certified Baro-VNAV
- Requires a WAAS GPS.
- LNAV/VNAV has a glide path.
- The glide path guarantees vertical guidance over obstacles, but the DA may be higher than the LNAV MDA.
- Use “LNAV/VNAV DA” approach minimums.

LPV DA		6104-1¼	291 (300-1¼)		
LNAV/VNAV DA		6152-1¼	339 (300-1¼)		
LNAV MDA	6260-1	447 (400-1)		6260-1¼	6260-1½



LNAV+V – *Lateral NAVigation + Vertical Navigation*

- Requires a WAAS GPS.
- LNAV+V annunciation infers that RAIM is OK.
- Non-precision approach with an **advisory** glide slope.
- Unlike the LNAV/VNAV glide path, the LNAV+V advisory glide path doesn't guarantee obstacle clearance. Instead, it provides guidance for a stabilized approach, and meets the MDA at the approach's VDP.
- Use “**LNAV MDA**” approach minimums.

DA	6152-1½ 339 (300-1¼)		
VNAV			
LNAV MDA	6260-1 447 (400-1)	6260-1½ 447 (400-1½)	6260-1½ 447 (400-1½)
CIRCLING	6440-1 555 (600-1)	6440-1½	6560-2¼

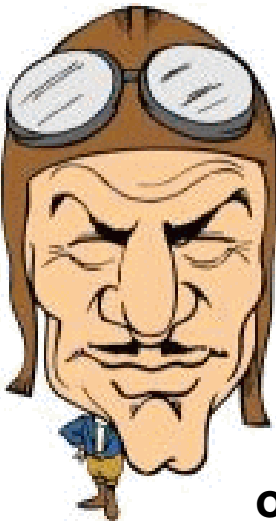

*There's a trap here if you're not careful. With the **advisory** glideslope, the LNAV approach looks an awful lot like an LPV approach. But if you keep flying the **advisory** glideslope after reaching the MDA (as you would on an LPV approach), you might hit something. After all, one reason an airport might only have an LNAV approach is obstacles on final that don't allow a more precise LPV approach. As the FAA declares:*

“The published VDA is for information only, advisory in nature, and provides no additional obstacle protection below the MDA”.

LNAV – *Lateral NAVigation*

DA	6152-1½ 339 (300-1¼)		
VNAV			
LNAV MDA	6260-1 447 (400-1)	6260-1½ 447 (400-1½)	6260-1½ 447 (400-1½)
CIRCLING	6440-1 555 (600-1)	6440-1½	6560-2¼



- WAAS or non-WAAS GPS.
- Use “**LNAV MDA**” approach minimums.
- Garmin 430W/530W difference: The LNAV annunciation appears when flying an LNAV GPS approach, ILS, or VOR.

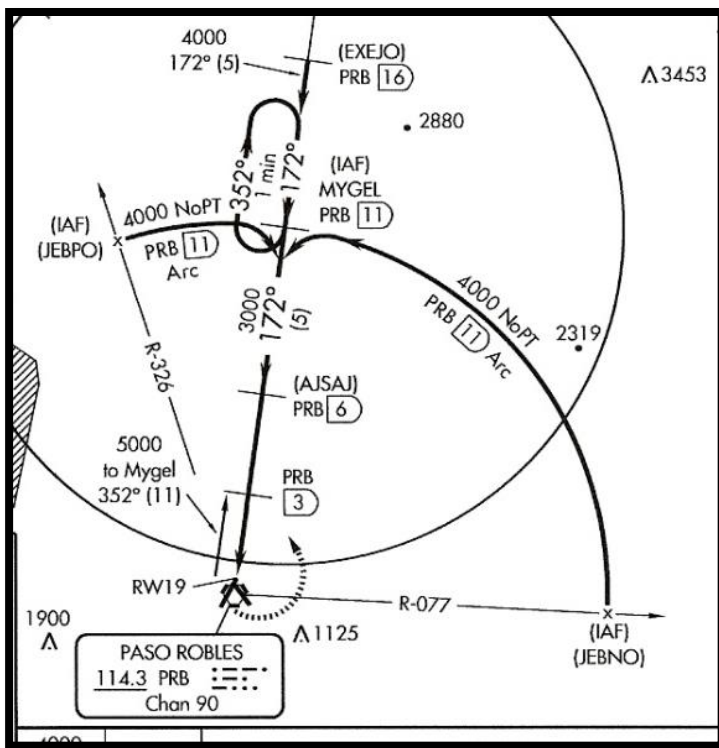

***NOTE:** If planning to fly an approach to LPV minimums, you should always be prepared for all the higher MDAs and DAs associated with the approach.*

***NOTE:** LPV, L/VNAV, LNAV+V, or LNAV may not annunciate until the aircraft is two miles outside the FAF.*

Baro – VNAV (Non-WAAS)

W11A	115°	Apt Elev	633	BUTLER COUNTY RGNI
▼	If local altimeter setting not received, use Cincinnati Muni Airport-Lunken Field altimeter setting and increase all DAs 59 feet and all MDAs 60 feet. Baro-VNAV NA when using Cincinnati Muni Airport-Lunken Field altimeter setting. For uncompensated Baro-VNAV systems, LNAV/VNAV NA below -16°C (4°F) or above 47°C (116°F). Visibility reduction by helicopters NA. DME/DME RNP-0.3 NA.			
▲				

References to “Baro-VNAV” are commonly found in approach notes. GPS units such as the GNS 430 and GNS 530 require baro-aiding as part of their installation. Most likely, if your GPS is connected to your altitude encoder, it has baro-aiding capability.

DME Arc Approaches

- Selecting an **IAF** from the approach menu, displays the arc on the GPS.
- If you plan to be vectored to the final approach course, (no arcing), select “Vectors” from the approach menu.

Reference this VOR/DME or GPS RWY 19 at KPRB, (Paso Robles, CA), there are two IAPs for the approach: **JEBNO** and **JEBPO**.

Finding Arc fixes for the GPS Arcing Approaches



“JEBNO” and “JEBPO” cannot be found in the database. Instead, the choices are “D077K” and “D326K”.

The VOR/DME or GPS RWY 19 approach uses the PRB 11 DME arc. Approach databases use a letter to represent the arc’s DME. See the table below.

Letters for DME Arc Distances		
A = 1	B = 2	C = 3
D = 4	E = 5	F = 6
G = 7	H = 8	I = 9
J = 10	K = 11	L = 12
M = 13	N = 14	O = 15
. . . . etc.		

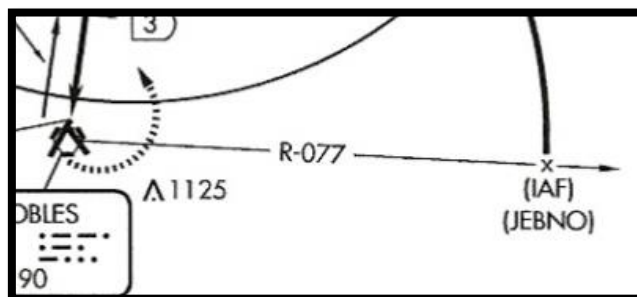

K is the 11th letter in the alphabet:

- D077K means the 077° radial, **11 DME** (JEBNO).
- D326K means the 326° radial, **11 DME** (JEBPO).

LDA with a Glide Slope

LDAs are in the database, but LDAs with a glide slope are NOT. You can still do something about that by using the LDA’s identifier.

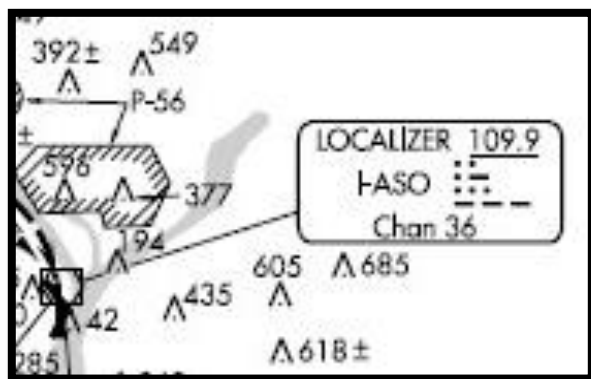

- In the flight plan, insert the LDA identifier just before the airport identifier. For instance, I-ASO would be entered as “**IASO**”, (drop the dash).
- Set the inbound LDA’s course in the “CRS” box.
- Set the inbound LDA course in the OBS and press **OBS**. (This creates a magenta line for the GPS map.)

Terminal Arrival Areas (TAAs)

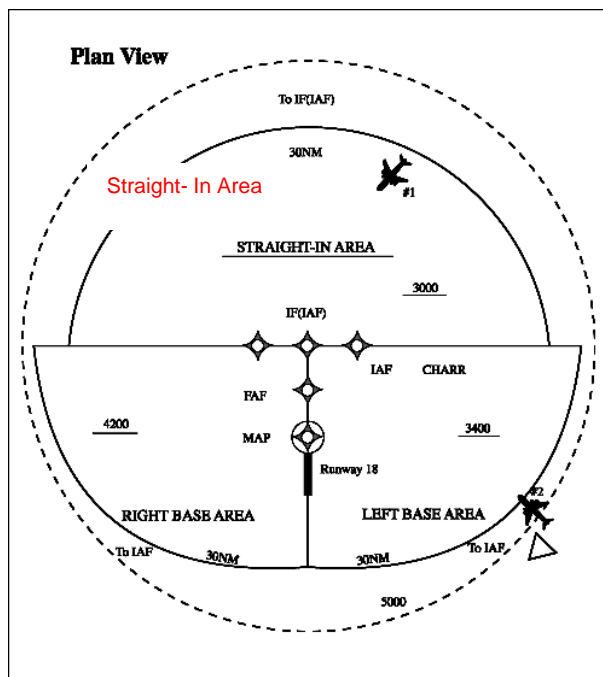

TAAs are not found on all RNAV procedures. However, when published, the TAA **replaces the MSA** for that approach procedure.

The "T" design uses one to three IAFs. Some locations omit a right-base or left-base area due to airspace or terrain considerations. There's also an intermediate fix (IF) that also serves as an IAF. It has a final approach fix (FAF) and a missed approach point (MAP), which is usually located at the runway threshold.

Pilots entering the TAA, and cleared by air traffic control, are expected to proceed directly to the appropriate IAF associated

with that area of the TAA, and at the altitude depicted, when within 30 NM of that fix.

(Ref. Dept. of Transportation, FAA, ATC Sect 8, 4-8-1)

Finding Your Area

Reference the RNAV (GPS) RWY 21L, Prescott, Arizona (KPRC) – next page.

The DUKIW and AKUHY TAAs form two 90° pieces of the pie.

- If flying a bearing of 90°, direct to DUKIW, you'd be in the **Right Base Area**.
- Once in the DUKIW TAA, you are expected to descend to 9,600 feet.
- If in the AKUHY TAA, (**Left Base Area**), you are expected to descend to 10,000 feet.
- The PEVYU TAA (**Straight-in Area**), has two MSAs; 11,400 feet (30 to 12 miles from PEVYU), and 9,100, (12 miles from PEVYU).
- Once passing DUKIW or AKUHY, note the 9,100' **NoPT** legs from DUKIW and AKUHY inbound to PEVYU.

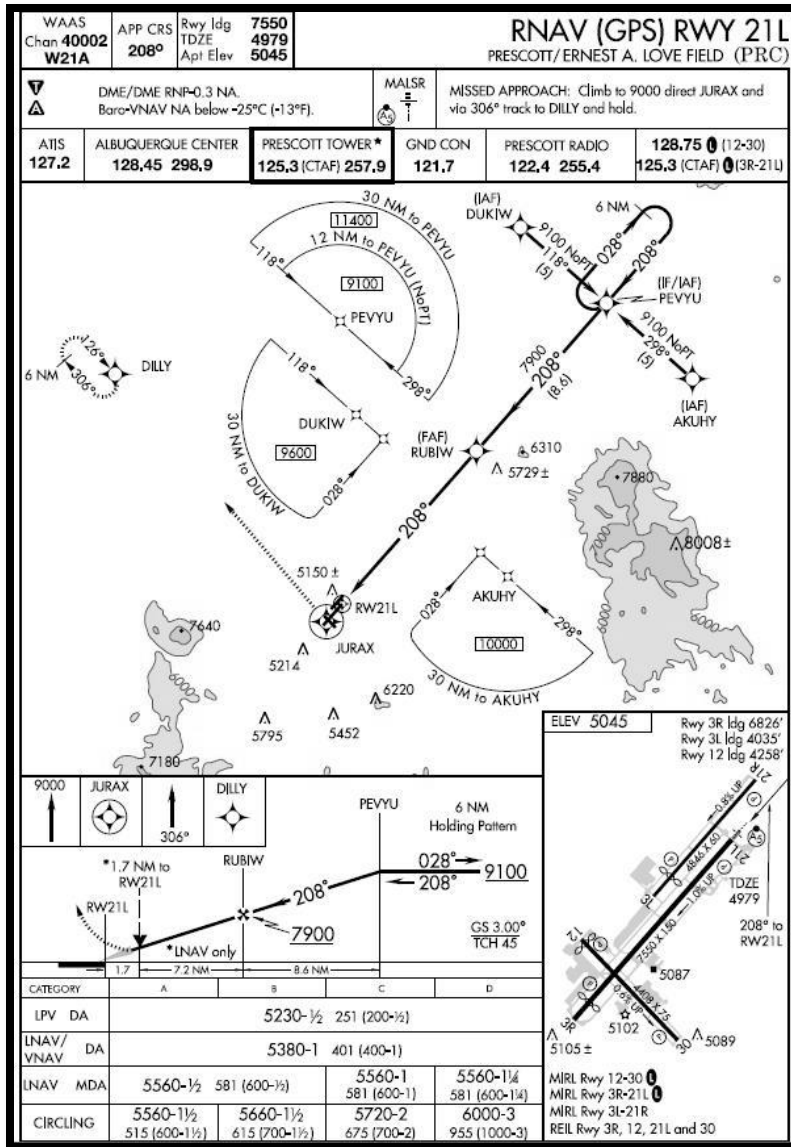

Hold in Lieu of Procedure Turns

Still referencing RNAV (GPS) RWY 21L – If you start the approach at the Intermediate Fix (IF) “PEVYU”, note that there’s a 4 nm racetrack pattern at PEVYU. **You MUST fly that pattern once.** (TAA pattern legs are defined in miles, not minutes).

If ATC does not want you to execute a procedure turn, the controller’s clearance will be, “Cleared direct PEVYU, maintain at or above nine thousand one hundred until PEVYU, cleared **straight-in** RNAV Runway Two One Left approach.” (Ref. Dept. of Transportation, FAA, ATC Sect 8, 4-8-1)

“NoPT” at the IF/IAF

Some straight-in areas specify “NoPT”.

Reference the RNAV GPS (RNAV) RWY 34 to Vernal, Utah (KVLEL), shown below.

If you are higher than 10,000 feet crossing the IF/IAF “OHAPE”, you could descend in the depicted racetrack, **but only if you’ve received permission from ATC.**

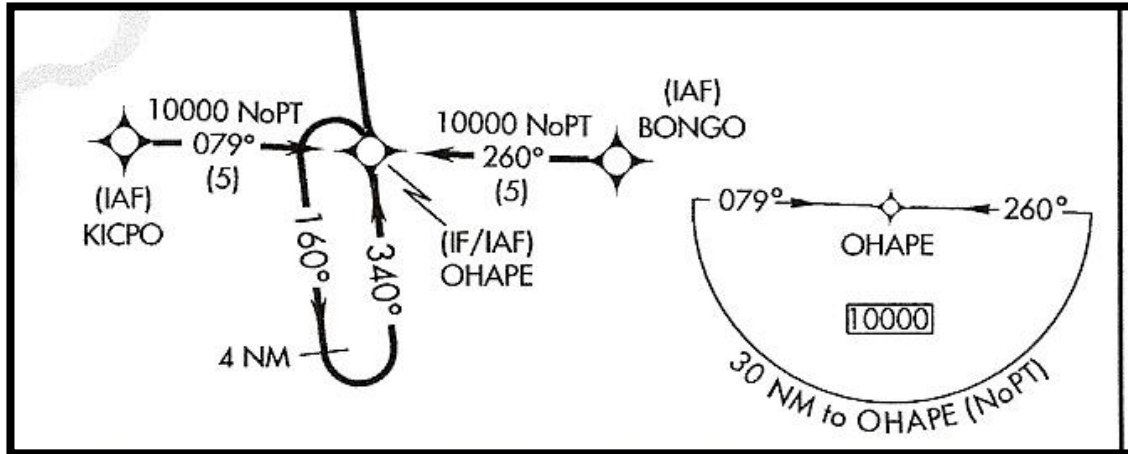

GNS 430 / 530 Missed Approach

- Brief the approach, scrolling through the approach and missed approach, checking for **conditional altitude requirements**. (Requirement to climb to an altitude before turning)
- Pressing the **OBS** key lets the GNS 430/530 accomplish the missed approach.
 - After passing the missed approach point, “SUSP” always appears above the **OBS** key.
 - After pressing **OBS**, “SUSP” will usually disappear and the course line for the missed approach will change from a thin line to a bold line.
- If you press **OBS**, and “SUSP” reappears, this means that you have not yet reached a conditional altitude. Do not press the **OBS** key again, until you satisfy the **conditional altitude requirement**.



ACTIVE FLIGHT PLAN		
00 KLMT / KLMT		
HAYPOINT	DTK	DIS
LMT		
5300	307°	2.3 _n _m
LMT		
8500	250°	5.0 _n _m

5,300 ft and 8,500 ft are missed approach **conditional altitude requirements** in this missed approach.



ILS Missed Approach Travel Tip

When performing a missed approach after a VOR, LOC or ILS approach, be sure to switch from the VOR or ILS/LOC signal, back to the GPS for missed approach guidance. (Press the CDI key).



Holding and Missed Approach Travel Tip

When holding is part of a missed approach procedure, the GNS 430/530 and GNS 430W/530W GPS units will remain “SUSPENDED” indefinitely. You must take action to Unsuspend and proceed with the Missed Approach Procedure

